

NO.	PARTS NAME	SIZE	REFERENCE
31	WATER OUTLET PIPE JOINT	Ø76.2	32696-01020
32	WATER OUTLET PIPE JOINT	Ø76.2	32696-01020
33	WATER DRAIN COCK		
34	OIL FULL-FLOW FILTER		
35	OIL BY-PASS FILTER		
36	THERMOMETER, ex. JOINT	RP3/4	32696-01020
37	EXHAUST FLANGE	200A	

NO.	PARTS NAME	SIZE	REFERENCE
1	FLYWHEEL & HOUSING		32696-21001
2	OIL PRESS. GAGE UNIT JOINT	Rc1/8	32696-01020
3	OIL PRESS. SWITCH JOINT	Rc1/8	
4	THERMOMETER UNIT JOINT	Rc1/2	
5	THERMOMETER UNIT JOINT	Rc1/2	
6	THERMOSWITIH JOINT	M16x1.5	
7	THERMOSWITIH JOINT	M16x1.5	
8	OIL PAN (A) JOINT	M20x1.5	
9	OIL PAN (A) JOINT	M20x1.5	
10	OIL PAN (A) JOINT	M20x1.5	
11	OIL PAN (A) JOINT	M20x1.5	
12	OIL PAN (B) JOINT	Rc3/4	
13	OIL PAN (C) JOINT	M36x1.5	
14	OIL PAN (D) JOINT		
15	OIL PAN (D) JOINT		
16	AIR PRESS. GAGE JOINT	Rc1/8	
17	AIR PRESS. GAGE JOINT	Rc1/8	
18	PICKUP JOINT	UNF5/8-18	
19	PICKUP JOINT	UNF5/8-18	
20	FUEL INLET PIPE JOINT	Rc3/4	
21	FUEL RETURN PIPE JOINT	Rc1/2	32696-01020
22	FUEL PRIMARY FILTER		
23	FUEL SECONDARY FILTER		
24	FUEL INJECTION PUMP		
25	GOVERNOR		
26	OIL LEVEL GAGE		
27	OIL FILLER		
28	OIL BY-PASS ALARM SWITCH	M5x0.8	32696-01020
29	BREATHER JOINT	Ø50.8	32696-01020
30	WATER INLET PIPE JOINT	80A	32696-01020

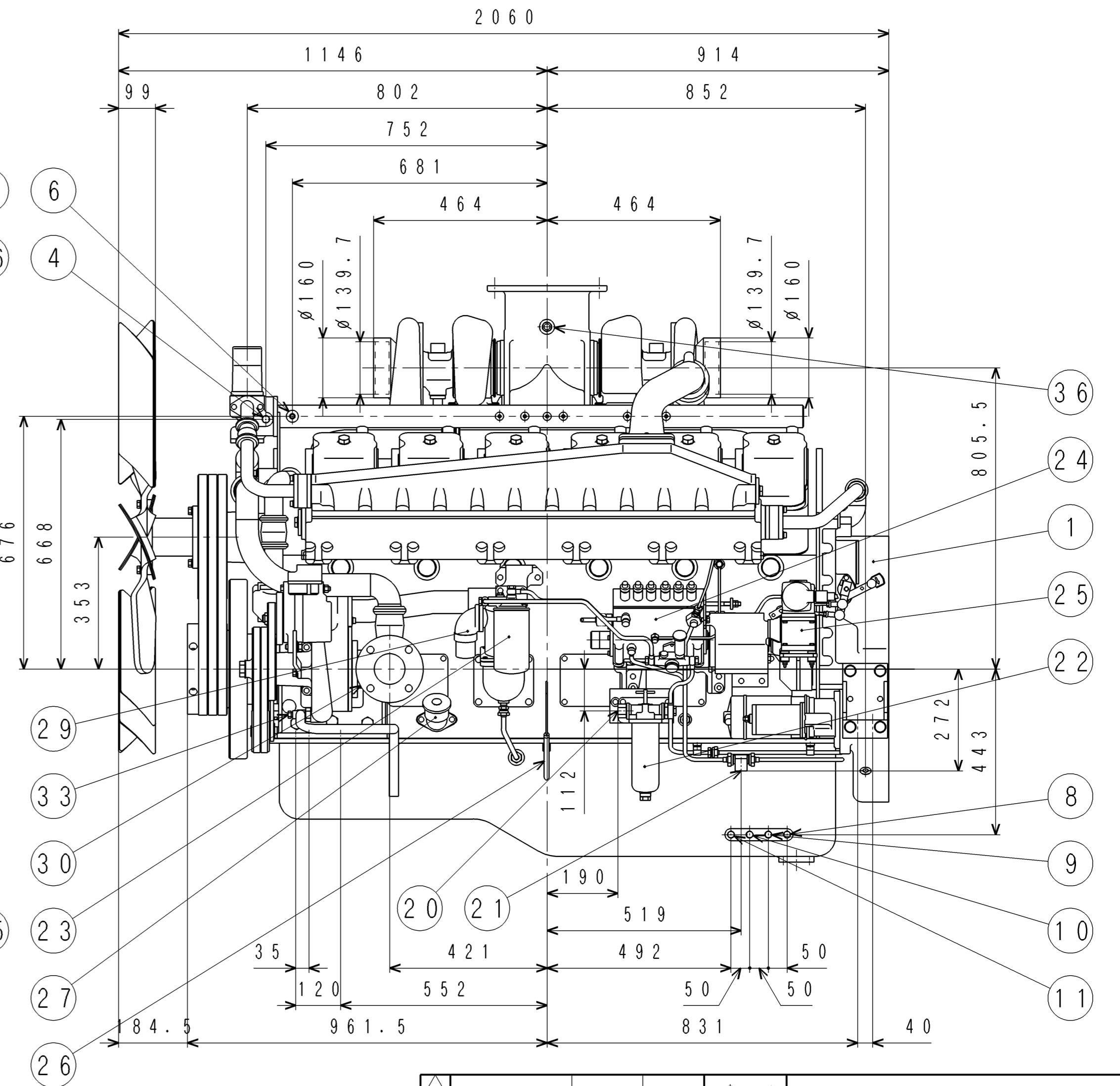
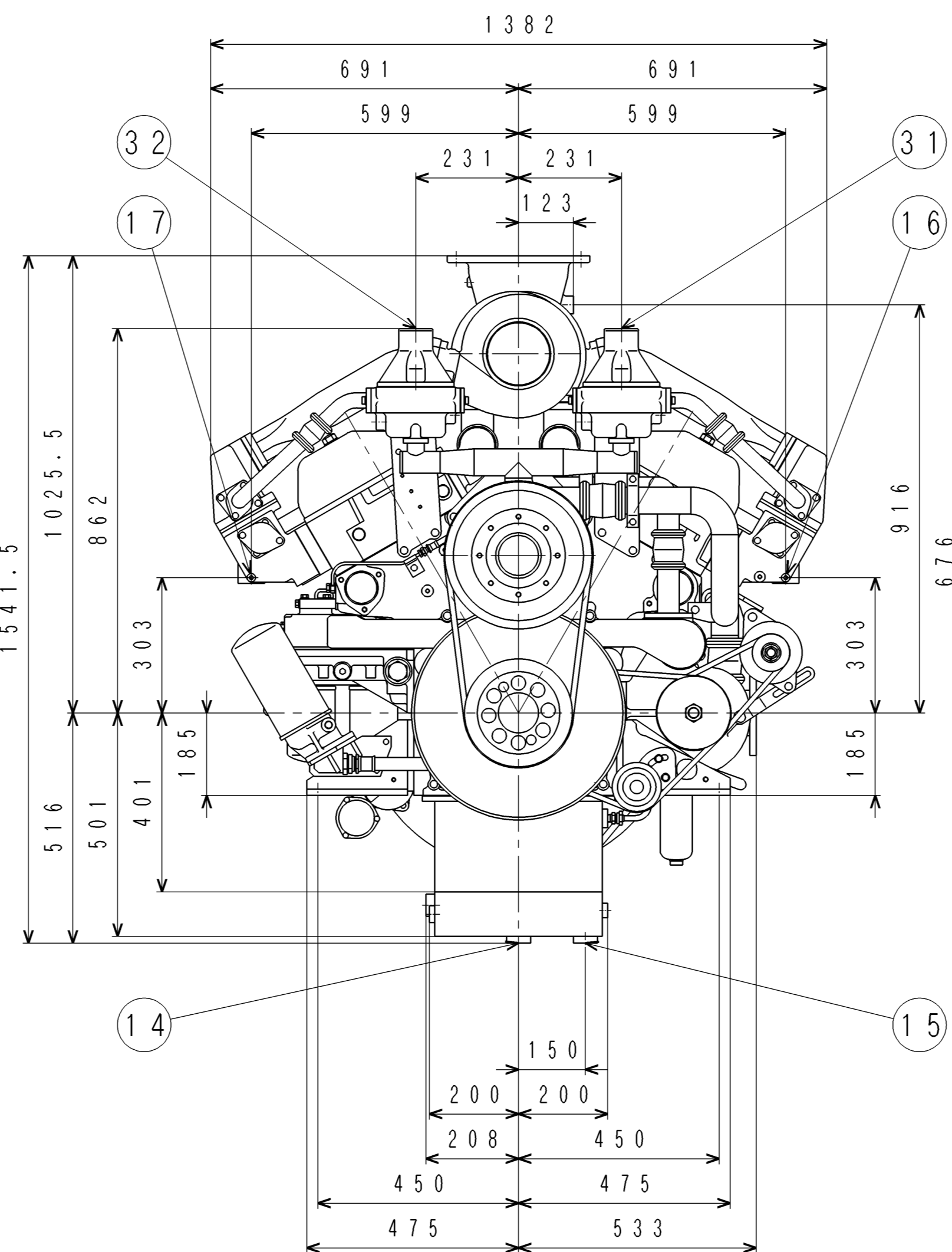
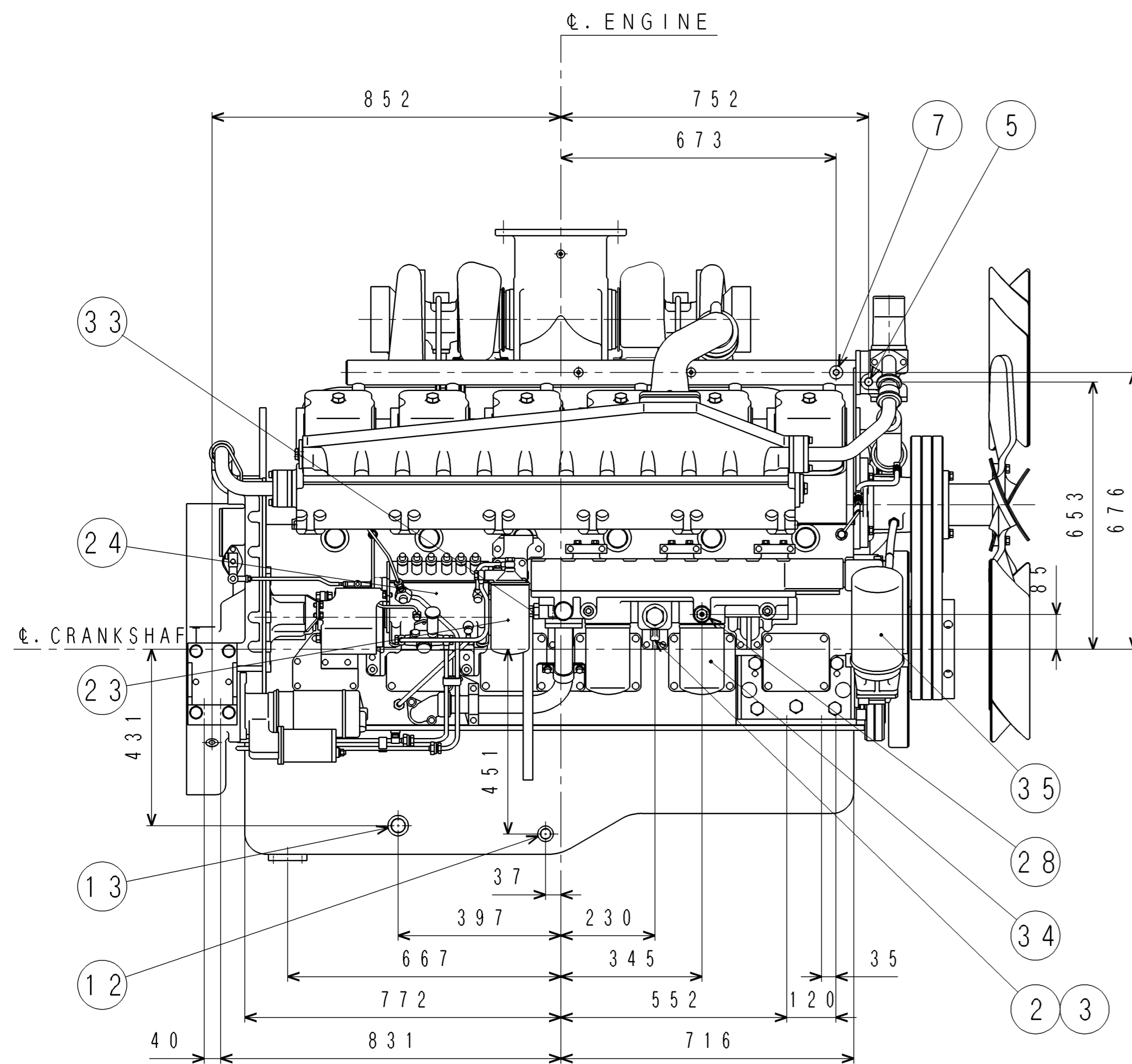
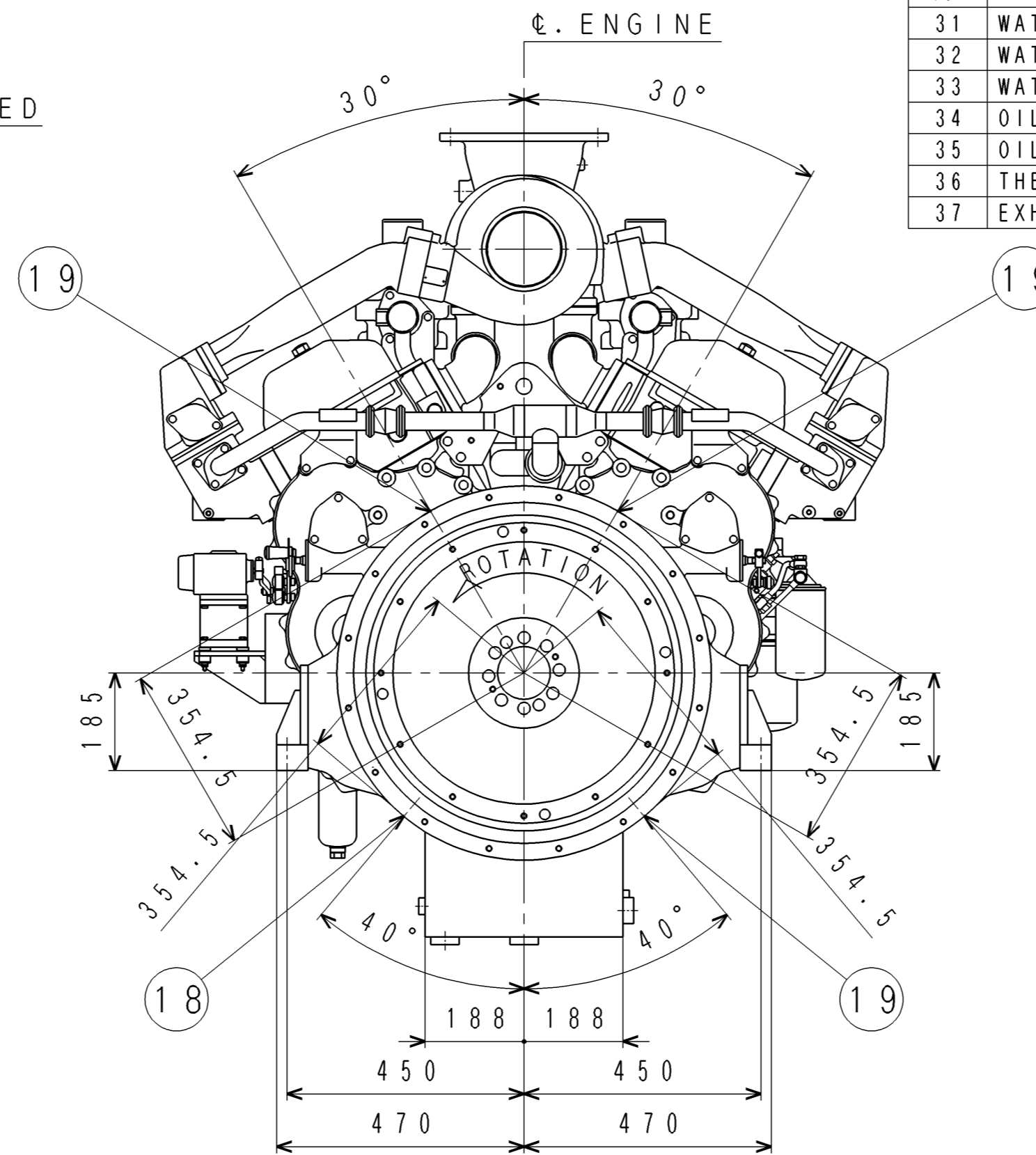
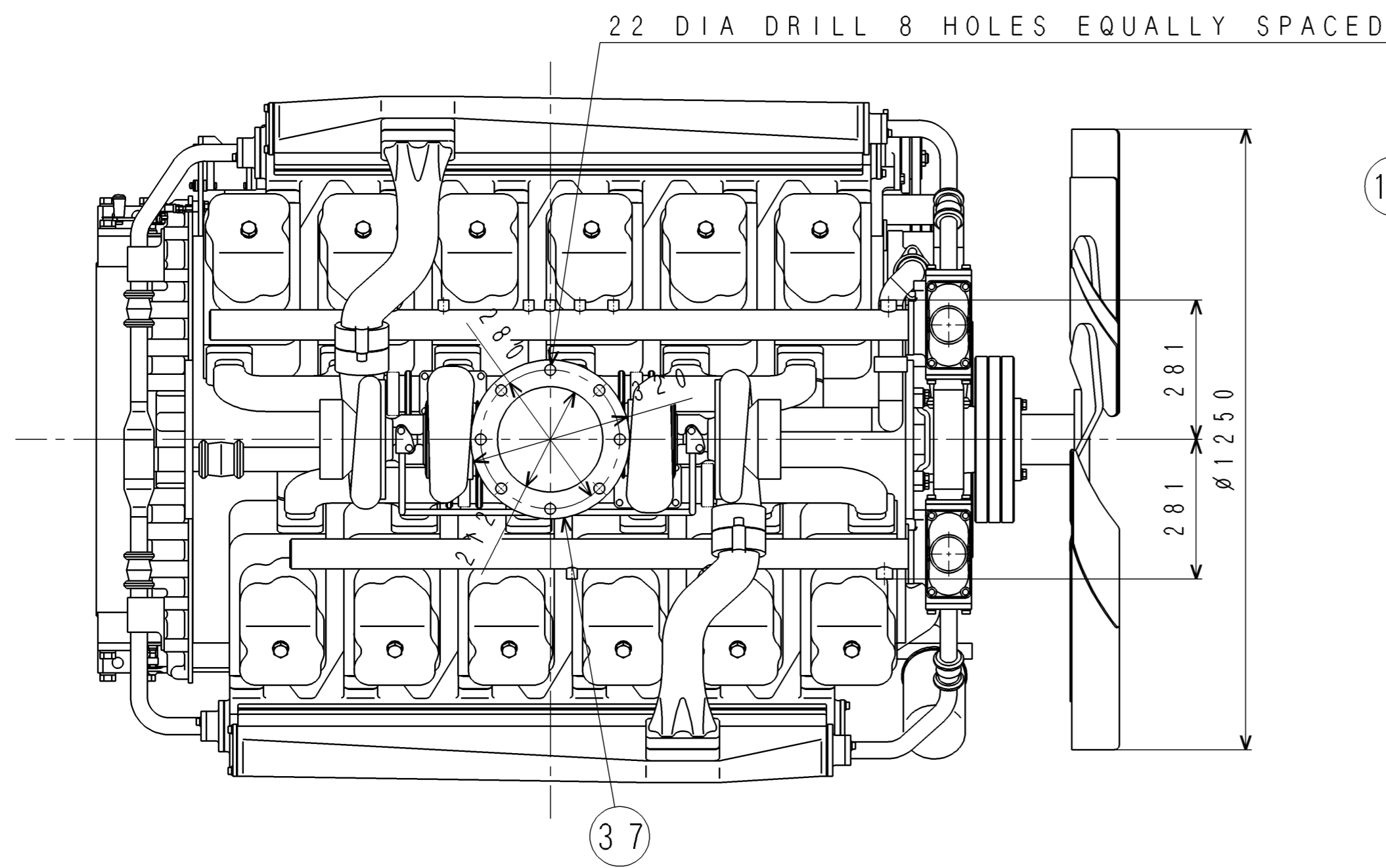

S12A2-PTA (CM-BR)		3rd ANGLE PROJECTION	
DIESEL ENGINE		尺度 SCALE	
三菱重工業株式会社相模原製作所		:	
SAGAMIHARA MACHINERY WORKS, MITSUBISHI HEAVY INDUSTRIES, LTD.		製図 谷 藤	
図面番号 32696-00220		製図 谷 藤	
DRAWING NO. 32696-00220		製図 谷 藤	
1998. 5. 8		製図 谷 藤	
3 製図 谷 藤		製図 谷 藤	
① 旧引図		製図 谷 藤	
A 1		製図 谷 藤	
相立図		製図 谷 藤	
1 5 切取品		製図 谷 藤	
6 その他 (購入品)		製図 谷 藤	

旧引  
三  
汎特  
2000  
4.28

FULL-CAO





**MITSUBISHI DIESEL ENGINE  
TECHNICAL INFORMATION**

ITEM NO.

T0213-0001E Rev.2 (1/4)

DATE

January, 2014

Specification Sheets of S12A2-PTA Engine

Specification Sheets of S12A2-PTA Engine are enclosed herein.

Revision

First Edition : September, 2007 (T13-0303-E Jun.99)

Rev.1 : Mar., 2013

Rev.2 : Jan., 2014

Engine Engineering Department  
High Speed Engine Designing Section

Approved by

Checked by

Drawn by

T.HASHIGUCHI

T.OGURA

K.NAKAMURA

## GENERAL ENGINE DATA

Type	4-Cycle, Water Cooled	
Aspiration	Turbo-Charged, After Cooler (Jacket water to Cooler)	
Cylinder Arrangement	60°V	
No. of Cylinders	12	
Bore mm(in.)	150	(5.91)
Stroke mm(in.)	160	(6.30)
Displacement liter(in <sup>3</sup> )	33.93	(2071)
Compression Ratio	14.5:1	
Dry Weight - Engine only - kg(lb)	3400	(7497)
Wet Weight - Engine only - kg(lb)	3620	(7982)

## PERFORMANCE DATA

## Steady State Speed Stability Band at any Constant Load

Hydraulic (std.) or Electric Governor - %	±0.25 or better	
Maximum Overspeed Capacity - rpm	2400	
Moment of inertia of Rotating Components - kgf·m <sup>2</sup> (lbf·ft <sup>2</sup> )	37.7	(895)
(Includes Std. Flywheel)		
Cyclic Speed Variation with Flywheel at 1800rpm	1/569	
1500rpm	1/335	
1200rpm	1/214	

## ENGINE MOUNTING

Maximum Bending Moment at Rear Face of Flywheel Housing - kgf·m(lbf·ft)	200	(1447)
---	-----	--------

## AIR INLET SYSTEM

## Maximum Intake Air Restriction (Includes piping)

With Clean Filter Element - mm H <sub>2</sub> O (in. H <sub>2</sub> O)	400	(15.7)
With Dirty Filter Element - mm H <sub>2</sub> O (in. H <sub>2</sub> O)	635	(25.0)

## EXHAUST SYSTEM

Maximum Allowable Back Pressure - mm H <sub>2</sub> O (in. H <sub>2</sub> O)	600	(23.6)
--	-----	--------

## LUBRICATION SYSTEM

Oil Pressure at Idle - kgf/cm <sup>2</sup> (psi)	2~3 (29~43)	
at Rate Speed - kgf/cm <sup>2</sup> (psi)	5~6 (71~86)	
Maximum Oil Temperature - °C(°F)	110	(230)
Oil Capacity of Standard Pan High - liter (U.S. gal)	100	(26.4)
Low - liter (U.S. gal)	80	(21.1)
Total System Capacity (Includes Oil Filter) - liter (U.S. gal)	120	(31.7)
Maximum Angle of Installation (Std. Pan)	Front Down	9.5°
(Engine Only)	Front Up	11°
	Side to Side	22.5°

## COOLING SYSTEM

Coolant Capacity (Engine only) - liter (U.S. gal)	100	(26.4)
Maximum External Friction Head at Engine Outlet - kgf/cm <sup>2</sup> (psi)	0.35	(5.0)
Maximum Static Head of Coolant above Crankshaft Center - m(ft)	10	(32.8)
Maximum Outlet Pressure of Engine Water Pump - kgf/cm <sup>2</sup> (psi)	1.7	(24.3)
Standard Thermostat (modulating) Range - °C(°F)	65~85	(149~185)
Maximum Coolant Temperature at Engine Outlet - °C(°F)	98	(208)
Minimum Coolant Expansion Space - % of System Capacity	10	
Maximum Coolant Temperature at Intercooler Inlet, TK type - °C(°F)	-	
Maximum Air Restriction on Discharge Side of Radiator and Fan - mm H <sub>2</sub> O(in. H <sub>2</sub> O)	10	(0.4)

The specifications are subject to change without notice.

APPLICATION : GENERATOR

Pub. No. T0213-0001E Rev.2 2/4

## FUEL SYSTEM

Fuel Injector	_____	Bosch P Type × 2
Maximum Suction Head of Feed Pump - mm Hg (in. Hg)	_____	75 (3.0)
Maximum Static Head of Return & Leak Pipe - mm Hg (in.Hg)	_____	150 (5.9)

## STARTING SYSTEM

Battery Charging Alternator - V- Ah	_____	24-25
Starting Motor Capacity - V - kW	_____	24-6.0 × 2
Maximum Allowable Resistance of Cranking Circuit - m Ω	_____	1.5
Recommended Minimum Battery Capacity		
At 5°C (41°F) and above - Ah	_____	300
Below 5°C (41°F) through - 5°C (23°F)	_____	500

The specifications are subject to change without notice.

APPLICATION : GENERATOR

Pub. No. T0213-0001E Rev.2 3/4

**S12A2-PTA**

**SPECIFICATION SHEET**

**ENGINE RATING**

All data represent net performance with standard accessories such as air cleaner, inlet /exhaust manifolds, fuel oil system, L.O. pump, etc. under the condition of 100kPa(29.6inHg) barometric pressure, 77°F(25°C) ambient temperature and 30% relative humidity.

ITEM	UNIT	EMERGENCY POWER	STAND-BY POWER				PRIME POWER			CONTINUOUS C		CONTINUOUS D	
		60Hz	60Hz	50Hz	60Hz	60Hz	50Hz	60Hz	60Hz	50Hz	60Hz	50Hz	
Engine Speed	rpm	1800	1800	1500	1200	1800	1500	1200	1800	1500	1800	1500	
No. of Cylinders		12											
Bore	mm (in.)	150 (5.91)											
Stroke	mm (in.)	160 (6.30)											
Displacement	liter (in. <sup>3</sup> )	33.93 (2071)											
Brake Horse power without Fan	HP (kW)	1186 (885)	1140 (850)	1000 (746)	800 (597)	1020 (761)	910 (679)	730 (545)	860 (642)	780 (582)	760 (567)	690 (515)	
Brake Mean Effective Pressure without Fan	kgf/cm <sup>2</sup> (psi)	17.7 (252)	17.0 (242)	17.9 (255)	17.9 (255)	15.2 (216)	16.3 (232)	16.4 (233)	12.9 (183)	14.0 (199)	11.4 (162)	12.4 (176)	
Mean Piston Speed	m/s (ft/min)	9.6 (1890)	9.6 (1890)	8.0 (1575)	6.4 (1260)	9.6 (1890)	8.0 (1575)	6.4 (1260)	9.6 (1890)	8.0 (1575)	9.6 (1890)	8.0 (1575)	
Maximum Regenerative Power Absorption Capacity without Fan	HP (kW)	125 (93)	125 (93)	91 (68)	63 (47)	125 (93)	91 (68)	63 (47)	125 (93)	91 (68)	125 (93)	91 (68)	
Intake Air flow	m <sup>3</sup> /min (CFM)	78 (2754)	75 (2648)	64 (2260)	53 (1871)	67 (2366)	58 (2048)	48 (1695)	56 (1977)	50 (1766)	49 (1730)	44 (1554)	
Exhaust Gas Flow	m <sup>3</sup> /min (CFM)	207 (7309)	197 (6956)	170 (6003)	141 (4979)	177 (6250)	154 (5438)	127 (4484)	147 (5191)	132 (4661)	131 (4626)	116 (4096)	
Coolant Flow	liter/min (U.S. GPM)	1100 (291)	1100 (291)	1000 (264)	840 (222)	1100 (291)	1000 (264)	840 (222)	1100 (291)	1000 (264)	1100 (291)	1000 (264)	
Coolant Flow to Intercooler (TK only)	liter/min (U.S. GPM)	—	—	—	—	—	—	—	—	—	—	—	
Cooling Air Flow (Std. Fan)	m <sup>3</sup> /min (CFM)	1380 (48728)	1380 (48728)	1140 (40253)	870 (30720)	1380 (48728)	1140 (40253)	870 (30720)	1380 (48728)	1140 (40253)	1380 (48728)	1140 (40253)	
Fan Loss Horse Power (Std. Fan)	HP (kW)	40 (30)	40 (30)	30 (22)	20 (15)	40 (30)	30 (22)	20 (15)	40 (30)	30 (22)	40 (30)	30 (22)	
Radiated Heat to Ambient	kcal/hr (BTU/min)	58792 (3888)	56163 (3715)	48348 (3198)	40147 (2655)	50251 (3324)	43718 (2891)	36188 (2393)	41842 (2767)	37473 (2478)	37210 (2461)	33149 (2192)	
Heat Rejection to Coolant	kcal/hr (BTU/min)	489937 (32404)	468027 (30955)	402900 (26647)	334560 (22127)	418761 (27696)	364319 (24096)	301563 (19945)	348687 (23062)	312273 (20653)	310080 (20508)	276242 (18270)	
Heat Rejection to Inter Cooler (TK Version)	kcal/hr (BTU/min)	—	—	—	—	—	—	—	—	—	—	—	
Heat Rejection to Exhaust	kcal/hr (BTU/min)	650277 (43008)	616683 (40787)	518918 (34321)	450386 (29788)	551769 (36493)	465532 (30790)	400255 (26472)	452585 (29933)	399028 (26391)	405541 (26822)	352986 (23346)	
Noise Level (1 m height & distance) (excludes, Intake,Exhaust & Fan)	dB(A)	TBD	TBD	TBD	TBD	TBD	TBD	TBD	TBD	TBD	TBD	TBD	

The specifications are subject to change without notice.

APPLICATION : GENERATOR

Pub. No. T0213-0001E Rev.2 4/4



**MITSUBISHI DIESEL ENGINE  
TECHNICAL INFORMATION**

ITEM NO.

T0307-0004E Rev.1 (1/2)

DATE

July, 2006

Elastic data of S12A2 Engine

Elastic data of S12A2 Engine are enclosed herein.

Revision	First Edition : July, 2006 (Refer to ELASTIC-S12A2-PTA Oct.,2003, S12A2.0)	Engine Engineering Department Engine System Designing Section		
	Rev.1 : August, 2011	Approved by	Checked by	Drawn by
		T.HASHIGUCHI	T.TSUKAMOTO	K.NAKAMURA

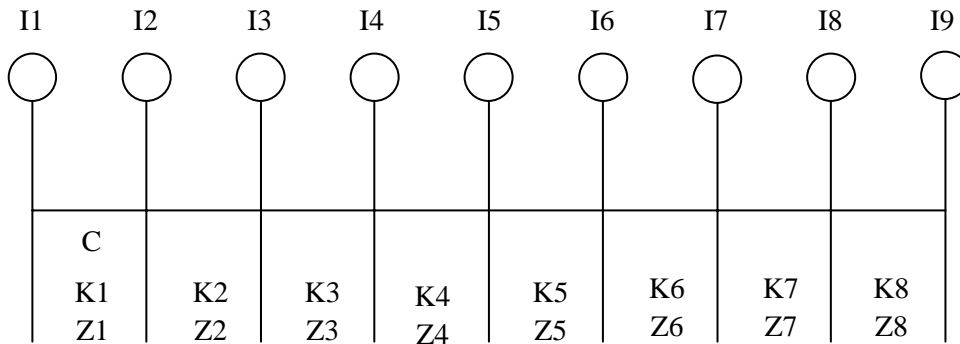
**S12A2-PTA ELASTIC DATA**

	Moment of inertia J kg.m <sup>2</sup>	Damping coefficient Nm/rad/s	Spring const. x10 <sup>7</sup> Nm/rad	Tensile strength N/mm <sup>2</sup>	Section modulus cm <sup>3</sup>
I1	DAMPER	1.11	C=587.4	K1=0	Z1 =0.0
I2	PULLEY	0.877	—	K2=0.655	Z2 =191.1
I3	No.1 CRANK	0.508	—	K3=0.406	Z3 =191.1
I4	No.2 CRANK	0.508	—	K4=0.406	Z4 =191.1
I5	No.3 CRANK	0.508	—	K5=0.406	Z5 =191.1
I6	No.4 CRANK	0.508	—	K6=0.406	Z6 =191.1
I7	No.5 CRANK	0.508	—	K7=0.406	Z7 =191.1
I8	No.6 CRANK	0.508	—	K8=0.664	Z8 =191.1
I9	FLYWHEEL 18in	5.15	—		

Hysteresis constant:188 No. of Cylinder: 12 Bore:150mm Stroke:160mm

Length of Con-Rod: 290mm Weight of Reciprocating Parts: 8.586 kg

Firing order:1-12-5-8-3-10-6-7-2-11-4-9

Firing interval:0-60-120-180-240-300-360-420-480-540-600-660

APPLICATION : LAND USE

The data is subject to change without notice.





**MITSUBISHI DIESEL ENGINE  
TECHNICAL INFORMATION**

ITEM NO.	T0402-0001E (1/2)
DATE	May, 2008

**Exhaust Gas Emission Data**

Exhaust Gas Emission Data is enclosed herein.

These data are subject to change without notice.

Revision	First Edition : May, 2008	Engine Engineering Department Large Engine Design Section		
		Approved by	Checked by	Drawn by
		T.HASHIGUCHI	H.MIKAMI	H.M.

## EXHAUST GAS EMISSION DATA OF DIESEL ENGINE FOR GENERATOR

NO. 021122

MODEL	S6A3-PTA		S12A2-PTA		S12H-PTA		S6R-PTA		S12R-PTA		S12R-PTA2		S12R-PTAA2(W/Fan)		S16R-PTA		S16R-PTA2		S16R-PTAA2(W/Fan)		
Prime Rating PS/rpm (without fan)	544 / 1500	625 / 1800	923 / 1500	1034/ 1800	1264/ 1500	1387/ 1800	700 / 1500	809 / 1800	1509 / 1500	1618 / 1800	1625/ 1500	1822/ 1800	1736/ 1500	1886/ 1800	2012 / 1500	2162 / 1800	2216 / 1500	2413 / 1800	2290/ 1500	2576/ 1800	
NO <sub>x</sub>	PPM	900	890	852	825	935	877	901	940	852	940	950	852	940	779	925	852	950	852	828	754
	g/Nm <sup>3</sup>	3.7	3.7	3.5	3.4	3.8	3.6	3.7	3.5	3.7	3.5	3.9	3.7	3.5	3.2	3.8	3.7	3.9	3.7	3.4	3.1
	g/PS·h	6.3	6.3	5.7	5.7	6.5	6.0	6.2	6.2	5.7	6.2	6.5	5.7	6.2	5.4	6.4	5.7	6.5	5.7	5.7	5.2
CO	PPM	(220)	(210)	(220)	(210)	(310)	(210)	310	210	(310)	(210)	(310)	(210)	(320)	(200)	(310)	(210)	(310)	(210)	(320)	(200)
	g/Nm <sup>3</sup>	(0.44)	(0.45)	(0.44)	(0.45)	(0.59)	(0.43)	0.52	0.39	(0.59)	(0.43)	(0.59)	(0.43)	(0.55)	(0.42)	(0.56)	(0.43)	(0.59)	(0.43)	(0.55)	(0.42)
	g/PS·h	(0.9)	1.0	(0.9)	1.0	(1.3)	(1.0)	1.1	0.9	(1.3)	(1.0)	(1.3)	(0.9)	(1.1)	(0.90)	(1.2)	(1.0)	(1.3)	(0.9)	(1.1)	(0.90)
HC	PPM	(50)	(50)	(50)	(50)	(110)	(120)	110	120	(110)	(120)	(110)	(120)	(110)	(120)	(110)	(120)	(110)	(120)	(110)	(120)
	g/Nm <sup>3</sup>	(0.05)	(0.06)	(0.05)	(0.06)	(0.11)	(0.13)	0.09	0.11	(0.11)	(0.13)	(0.11)	(0.13)	(0.10)	(0.13)	(0.10)	(0.13)	(0.11)	(0.13)	(0.10)	(0.13)
	g/PS·h	(0.11)	(0.13)	(0.11)	(0.13)	(0.23)	(0.28)	0.20	0.25	(0.23)	(0.28)	(0.23)	(0.26)	(0.21)	(0.28)	(0.21)	(0.28)	(0.23)	(0.26)	(0.21)	(0.28)
CO <sub>2</sub>	%	6.7	6.2	6.7	6.2	6.9	6.5	8.0	7.1	6.9	6.5	6.7	6.5	6.7	6.5	6.7	6.5	6.7	6.5	6.7	6.5
	g/PS·h	455	475	455	475	455	460	440	455	455	460	456	451	455	450	455	450	456	451	455	450
PM	g/Nm <sup>3</sup>	0.12	0.12	0.12	0.11	0.12	0.11	0.1	0.12	0.12	0.11	0.1	0.09	0.09	0.08	0.11	0.12	0.11	0.12	0.09	0.07
	g/PS·h	0.27	0.27	0.28	0.27	0.28	0.27	0.25	0.26	0.26	0.27	0.25	0.24	0.24	0.23	0.24	0.29	0.24	0.29	0.24	0.23

**Notes**

- |   |  |  |
|---|--|--|
| 1. Allowance : +25%<br>2. Condition : 100kPa (750mmHg) barometric pressure,<br>298K (25 ) ambient temperature and<br>30% relative humidity. | 3. NO <sub>x</sub> , CO, HC (PPM) : with 13% O <sub>2</sub> Level.<br>NO <sub>x</sub> , CO, HC, Particulates (g/Nm <sup>3</sup> ) : with 5% O <sub>2</sub> Level.<br>NO <sub>x</sub> , CO, HC, Particulates (g/PS·h) : with 13% O <sub>2</sub> Level.<br>CO <sub>2</sub> [%] : Calculated Data.<br>( ) : Estimated Data. | 4. These data are subject to change<br>without notice. |
|---|--|--|

ITEM NO.

T0402-0001E (2/2)



**MITSUBISHI DIESEL ENGINE  
TECHNICAL INFORMATION**

ITEM NO.

T33-0100-E

DATE

Jun. 1999

**FUEL CONSUMPTION**

(SB, SA, SH, SR SERIES ENGINES FOR GENERATOR DRIVE)

ENGINE MODEL	ENGINE rpm	REMARKS
S6B-PTA, PTK	1500	W/Fan, W/O Fan
	1800	
S6B3-PTA, PTK	1200	W/Fan, W/O Fan
	1500	
S6A3-PTA, PTK	1200	W/Fan, W/O Fan
	1500	
S12A2-PTA, PTK	1200	W/Fan, W/O Fan
	1500	
S12H-PTA	1500	W/Fan, W/O Fan
	1800	
S6R-PTA, PTK	1200	W/Fan, W/O Fan
	1500	
S6R2-PTA, PTK	1000	W/Fan, W/O Fan
	1200	
S12R-PTA, PTK	1200	W/Fan, W/O Fan
	1500	
S12R-PTA2, PTK2	1500	W/Fan, W/O Fan
	1800	
S16R-PTA, PTK	1200	W/Fan, W/O Fan
	1500	
S16R-PTA2, PTK2	1500	W/Fan, W/O Fan
	1800	
S6A3-PTAA	1500	W/Fan
	1800	
S6R2-PTAA	1500	W/Fan
S12R-PTAA2	1500	W/Fan
	1800	
S16R-PTAA2	1500	W/Fan
	1800	

First Edition : Jun. 1999

Engine Engineering Department  
Large Engine Design Section

Revision

Approved by

Checked by

Drawn by

# SPECIFIC FUEL CONSUMPTION MODEL : S6B 1500rpm

- 1. STANDARD : ISO or JIS
- 2. ALLOWANCE : +5%

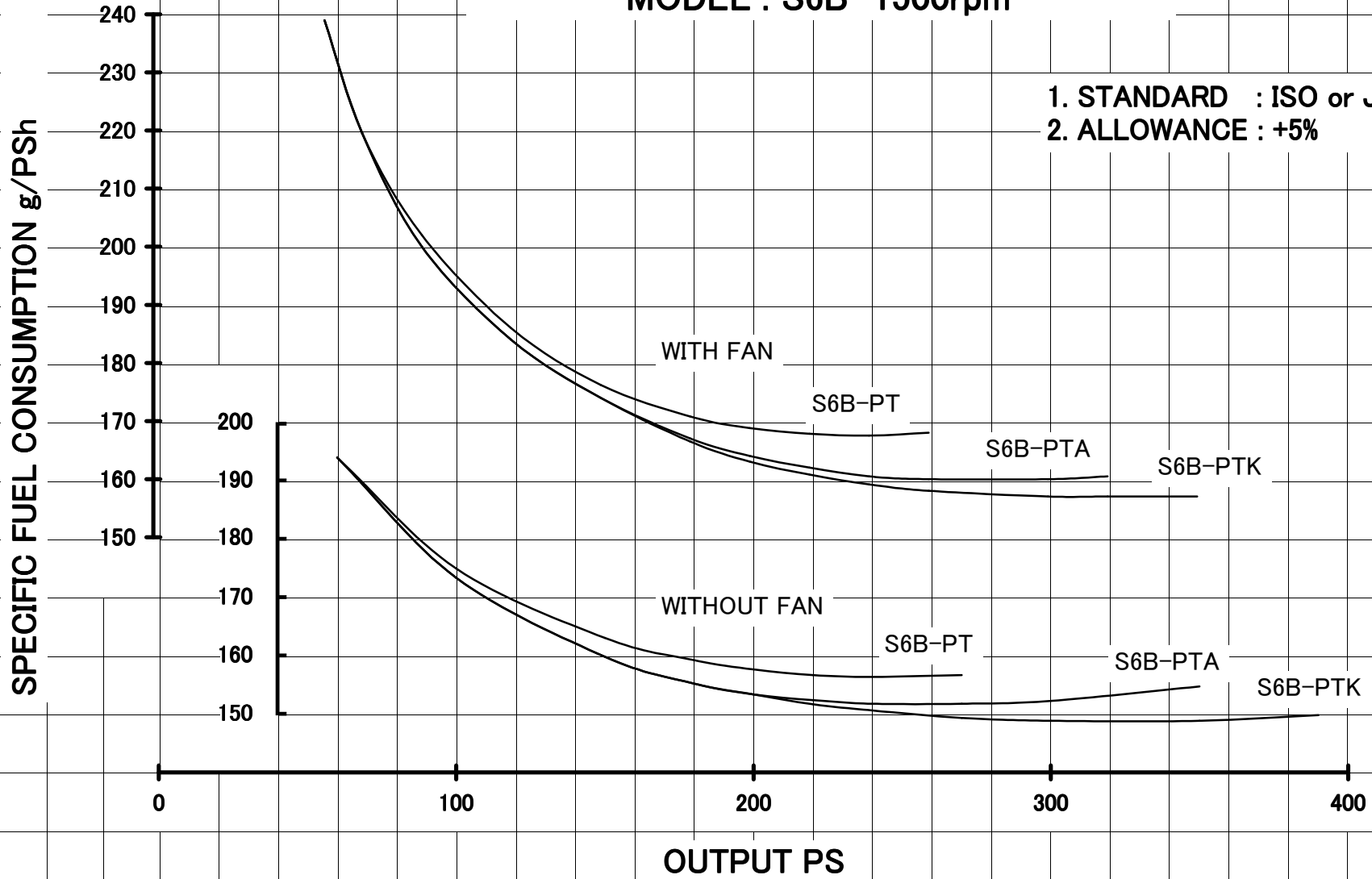

# SPECIFIC FUEL CONSUMPTION MODEL : S6B 1800rpm

- 1. STANDARD : ISO or JIS
- 2. ALLOWANCE : +5%

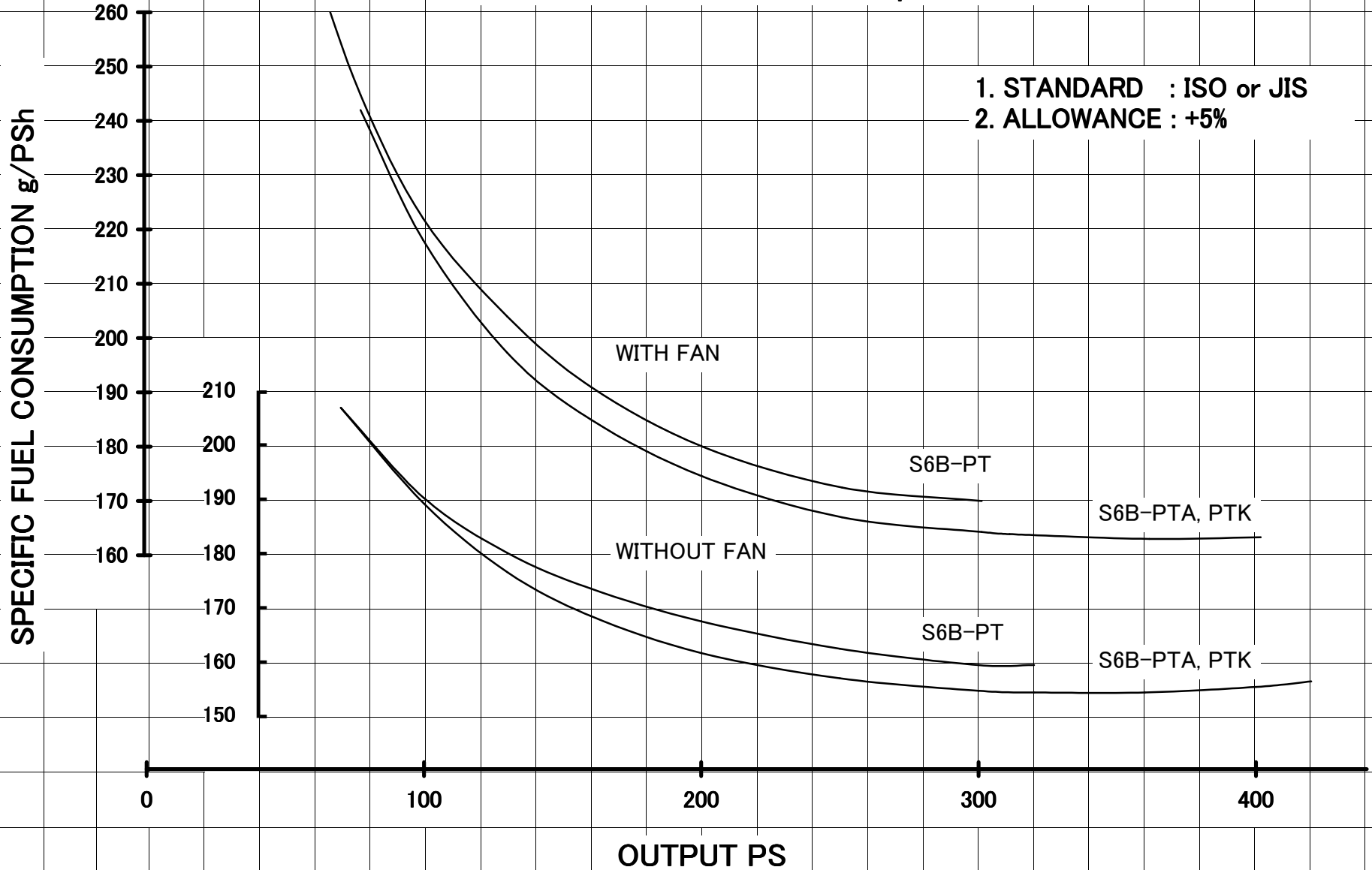

# SPECIFIC FUEL CONSUMPTION MODEL : S6B3 1200rpm

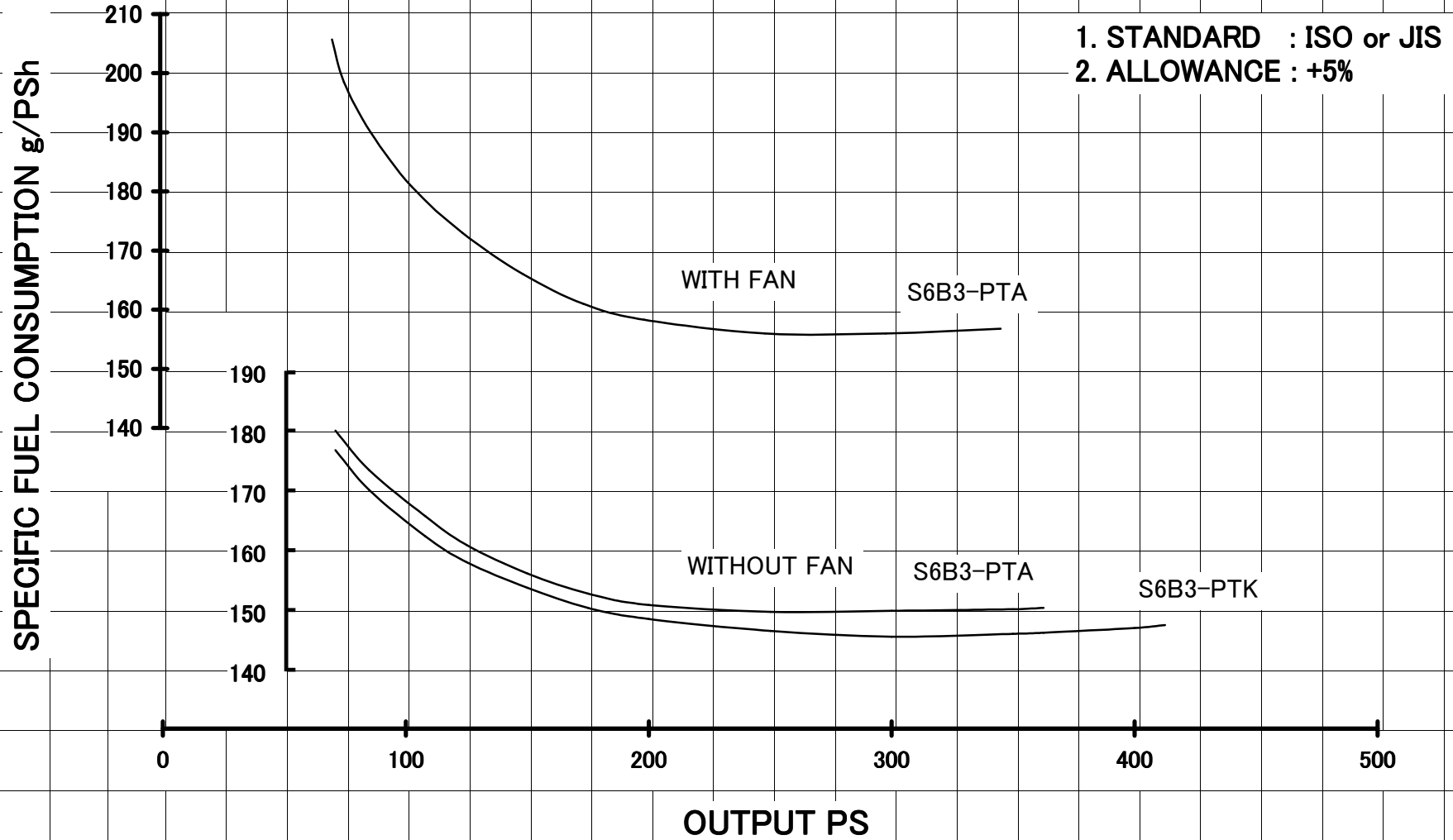

# SPECIFIC FUEL CONSUMPTION

MODEL : S6B3 1500rpm

1. STANDARD : ISO or JIS

2. ALLOWANCE : +5%

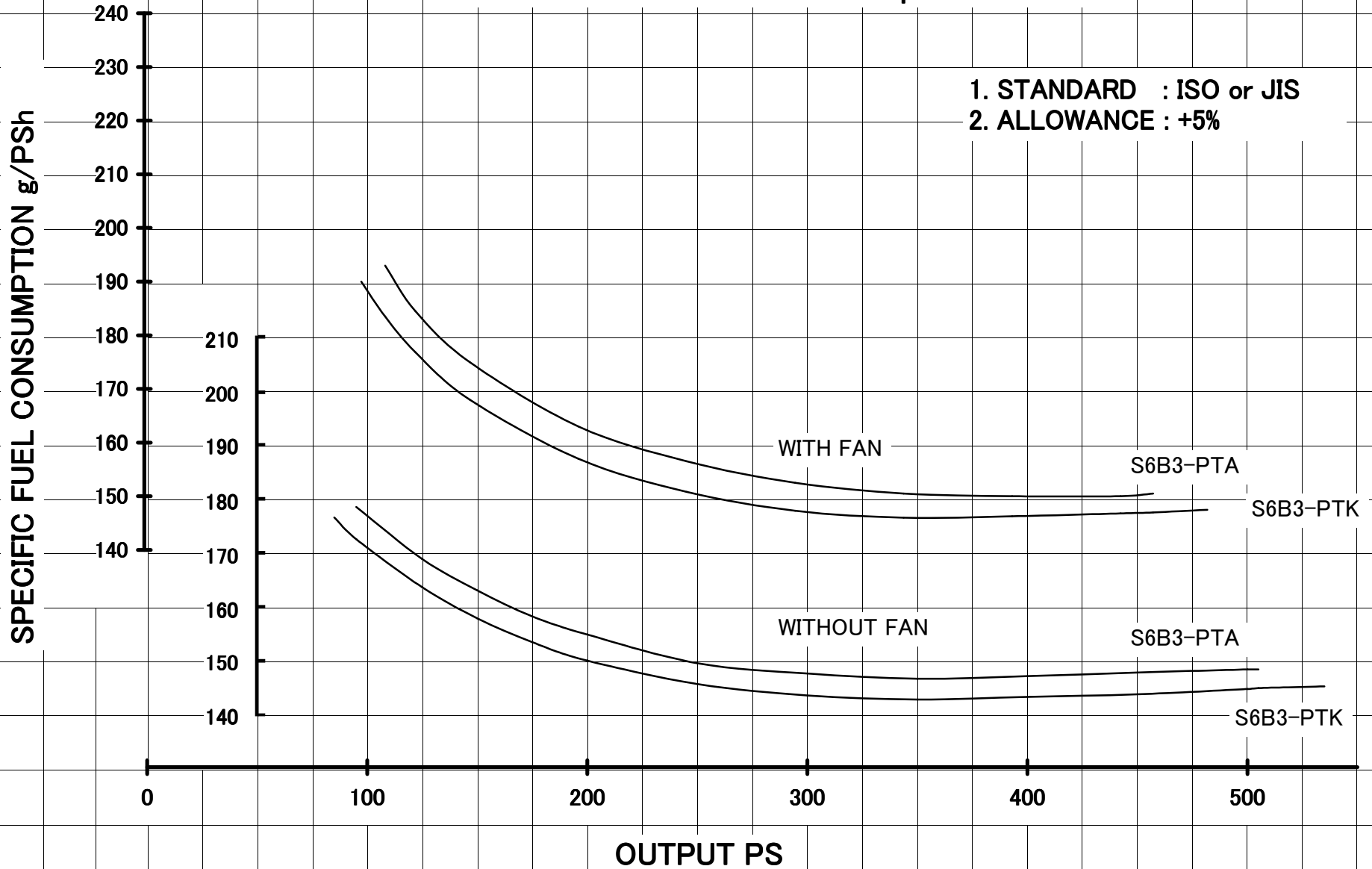

# SPECIFIC FUEL CONSUMPTION MODEL : S6B3 1800rpm

- 1. STANDARD : ISO or JIS
- 2. ALLOWANCE : +5%

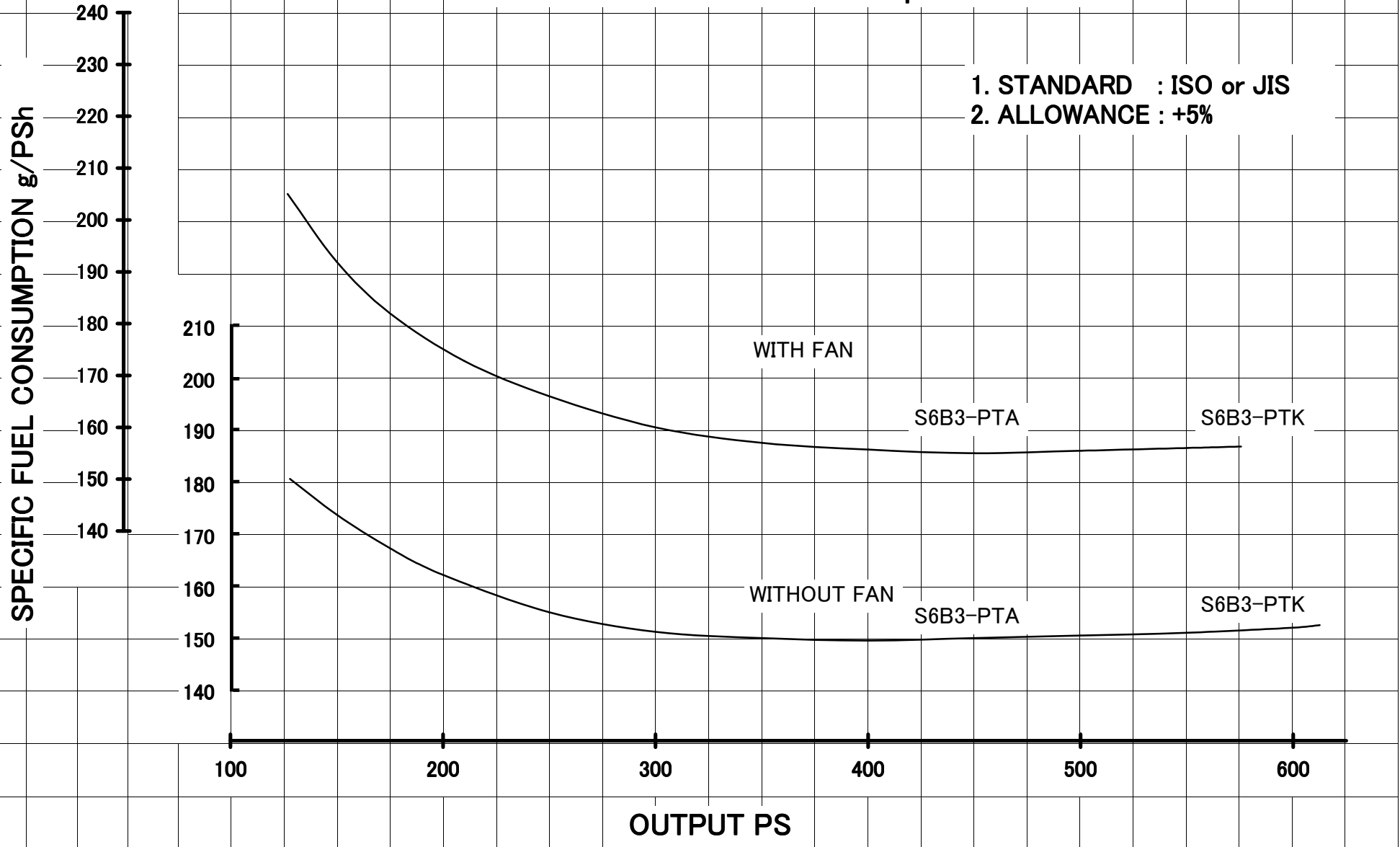



# SPECIFIC FUEL CONSUMPTION MODEL : S6A3 1200rpm

- 1. STANDARD : ISO or JIS
- 2. ALLOWANCE : +5%

SPECIFIC FUEL CONSUMPTION g/PS<sub>h</sub>

210  
200  
190  
180  
170  
160  
150  
140

190  
180  
170  
160  
150  
140

WITH FAN

WITHOUT FAN

S6BA3-PTA

S6A3-PTK

0 100 200 300 400 500

OUTPUT PS

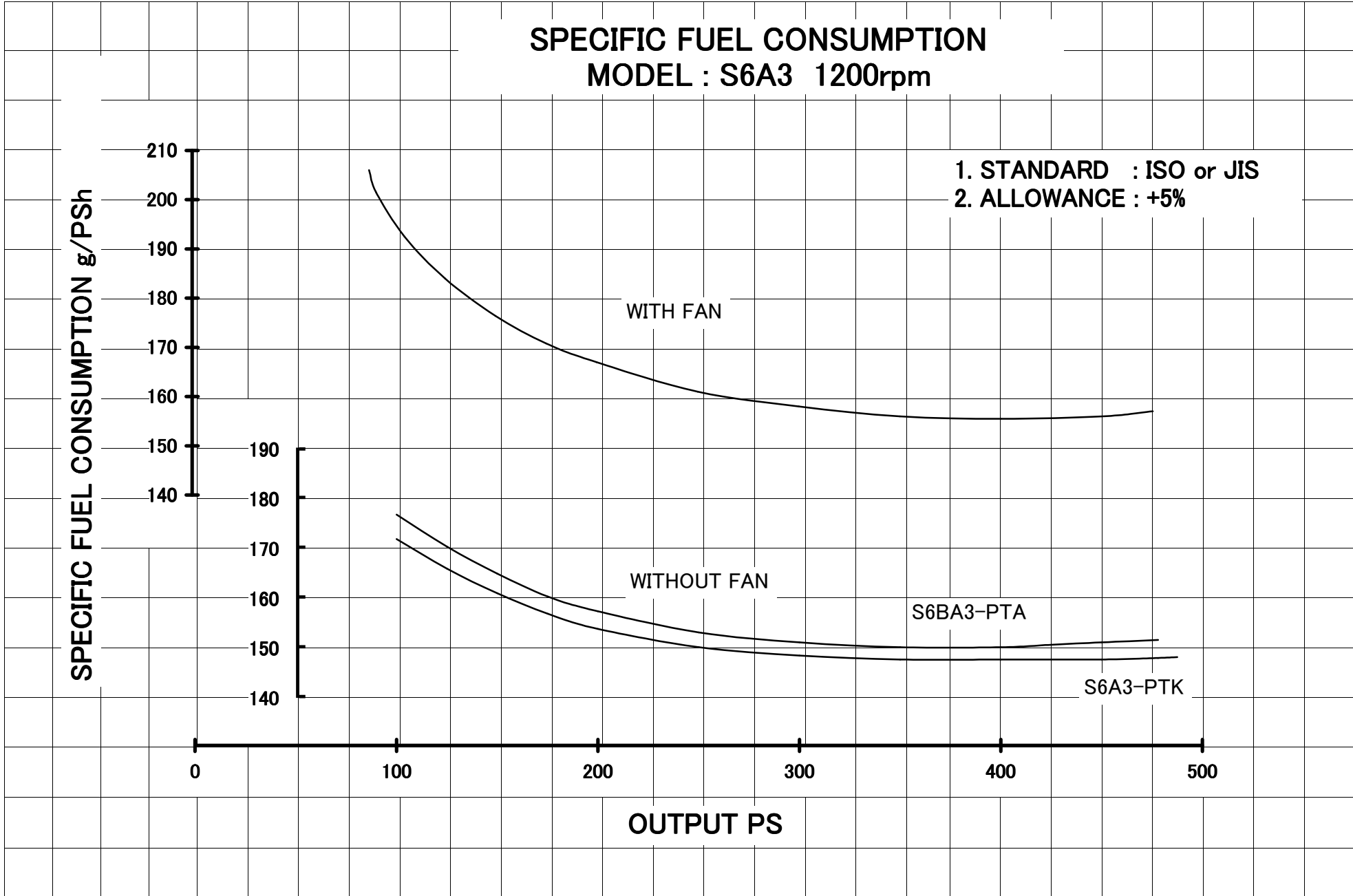

# SPECIFIC FUEL CONSUMPTION MODEL : S6A3 1500rpm

- 1. STANDARD : ISO or JIS
- 2. ALLOWANCE : +5%

SPECIFIC FUEL CONSUMPTION g/PS<sub>h</sub>

220  
210  
200  
190  
180  
170  
160  
150  
140

210  
200  
190  
180  
170  
160  
150  
140

WITH FAN

S6A3-PTA

S6A3-PTK

WITHOUT FAN

S6A3-PTA

S6A3-PTK

0 100 200 300 400 500 600 700

OUTPUT PS

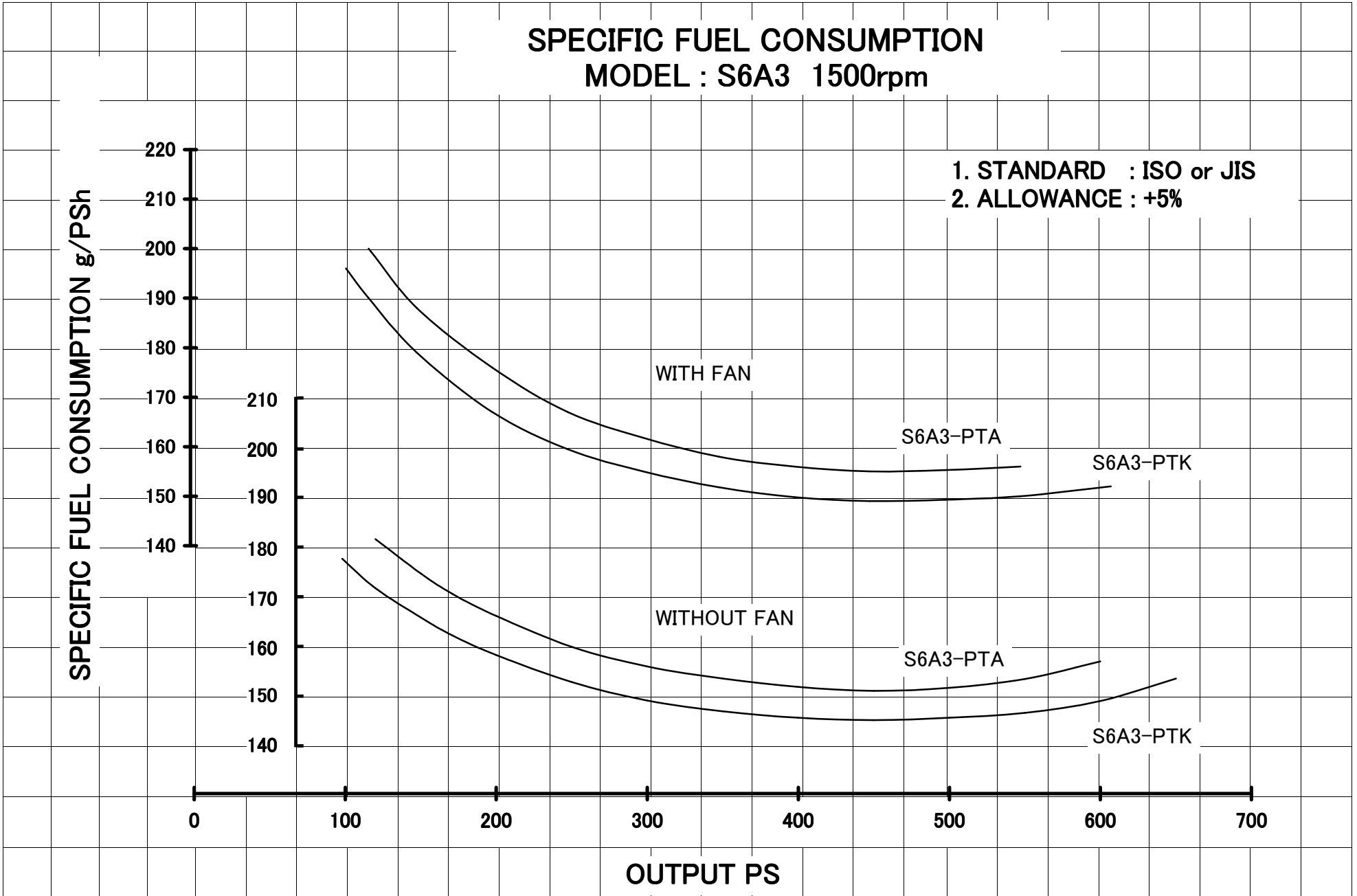

# SPECIFIC FUEL CONSUMPTION

MODEL : S6A3 1800rpm

- 1. STANDARD : ISO or JIS
- 2. ALLOWANCE : +5%

SPECIFIC FUEL CONSUMPTION g/PS<sub>h</sub>

230  
220  
210  
200  
190  
180  
170  
160  
150

210  
200  
190  
180  
170  
160  
150

WITH FAN

S6A3-PTA

S6A3-PTK

WITHOUT FAN

S6A3-PTA

S6A3-PTK

0

100

200

300

400

500

600

700

OUTPUT PS

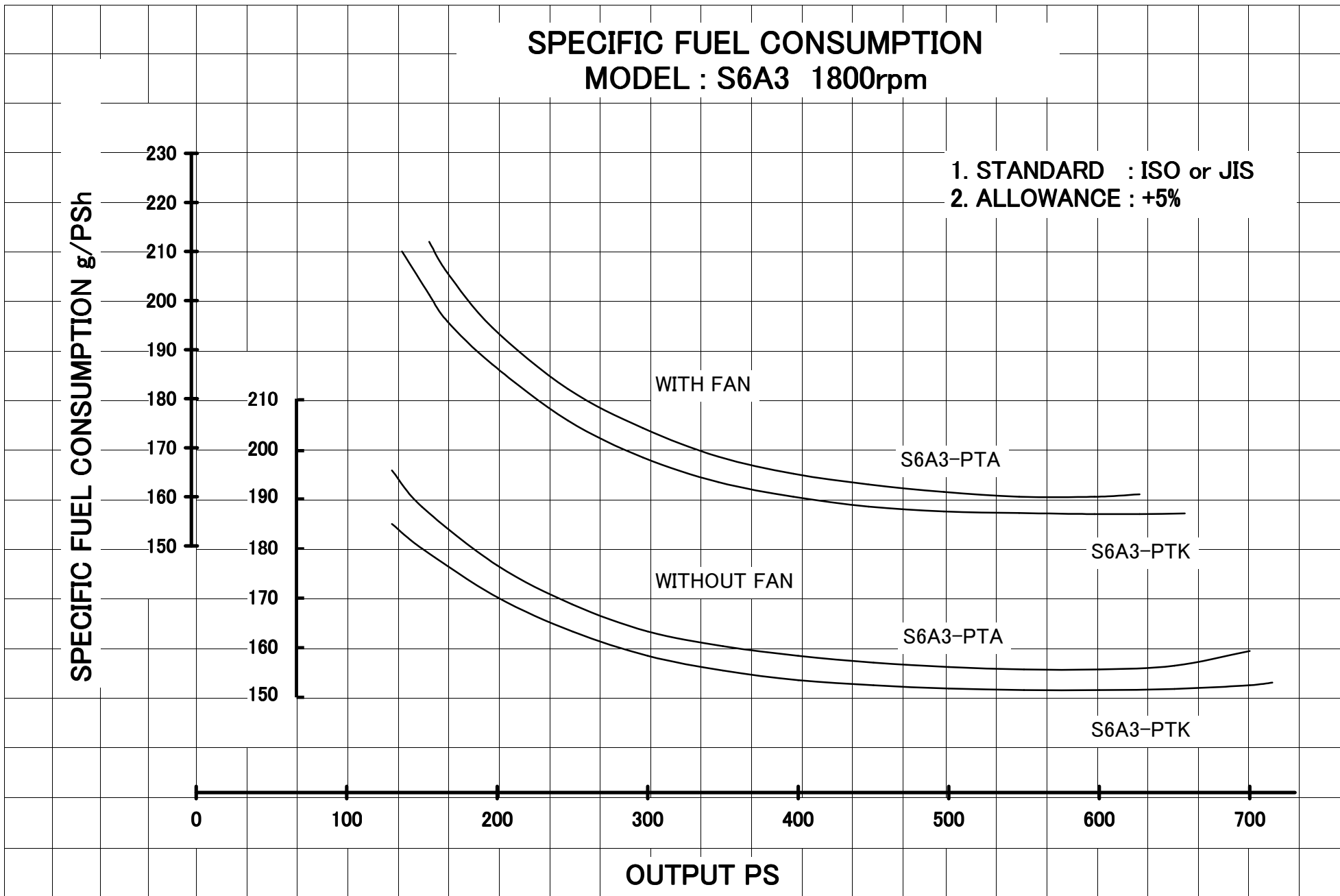

# SPECIFIC FUEL CONSUMPTION MODEL : S12A2 1200rpm

- 1. STANDARD : ISO or JIS
- 2. ALLOWANCE : +5%

SPECIFIC FUEL CONSUMPTION g/PS<sub>h</sub>

190  
180  
170  
160  
150

180  
170  
160  
150

0

200

400

600

800

OUTPUT PS

WITH FAN

S12A2-PT

S12A2-PTA

S12A2-PTK

WITHOUT FAN

S12A2-PT

S12A2-PTA

S12A2-PTK

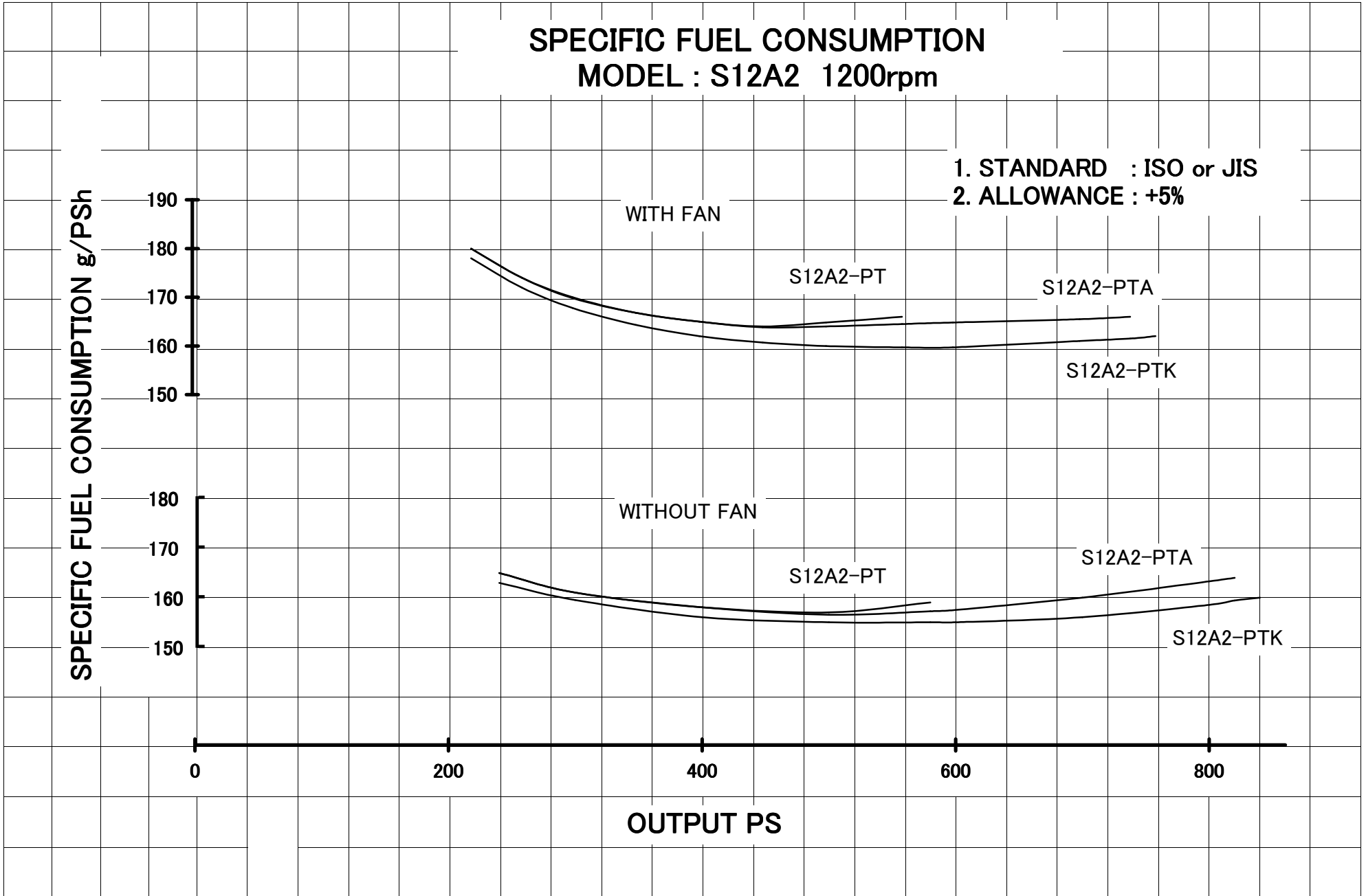

# SPECIFIC FUEL CONSUMPTION MODEL : S12A2 1500rpm

- 1. STANDARD : ISO or JIS
- 2. ALLOWANCE : +5%

SPECIFIC FUEL CONSUMPTION g/PS<sub>h</sub>

190  
180  
170  
160  
150

190  
180  
170  
160  
150  
140

0

200

400

600

800

1000

OUTPUT PS

WITH FAN

S12A2-PT

S12A2-PTA

S12A2-PTK

WITHOUT FAN

S12A2-PT

S12A2-PTA

S12A2-PTK

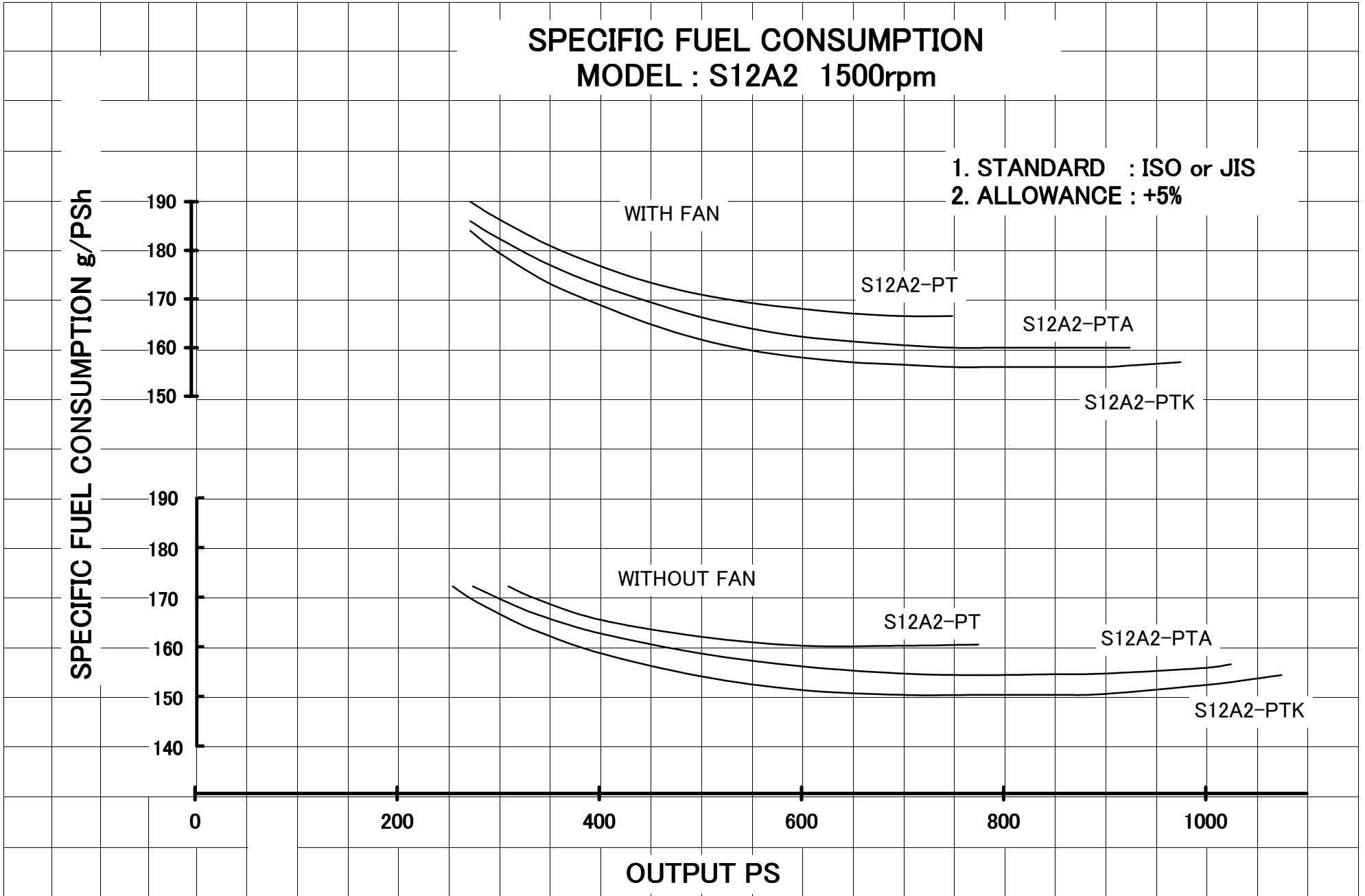

# SPECIFIC FUEL CONSUMPTION MODEL : S12A2 1800rpm

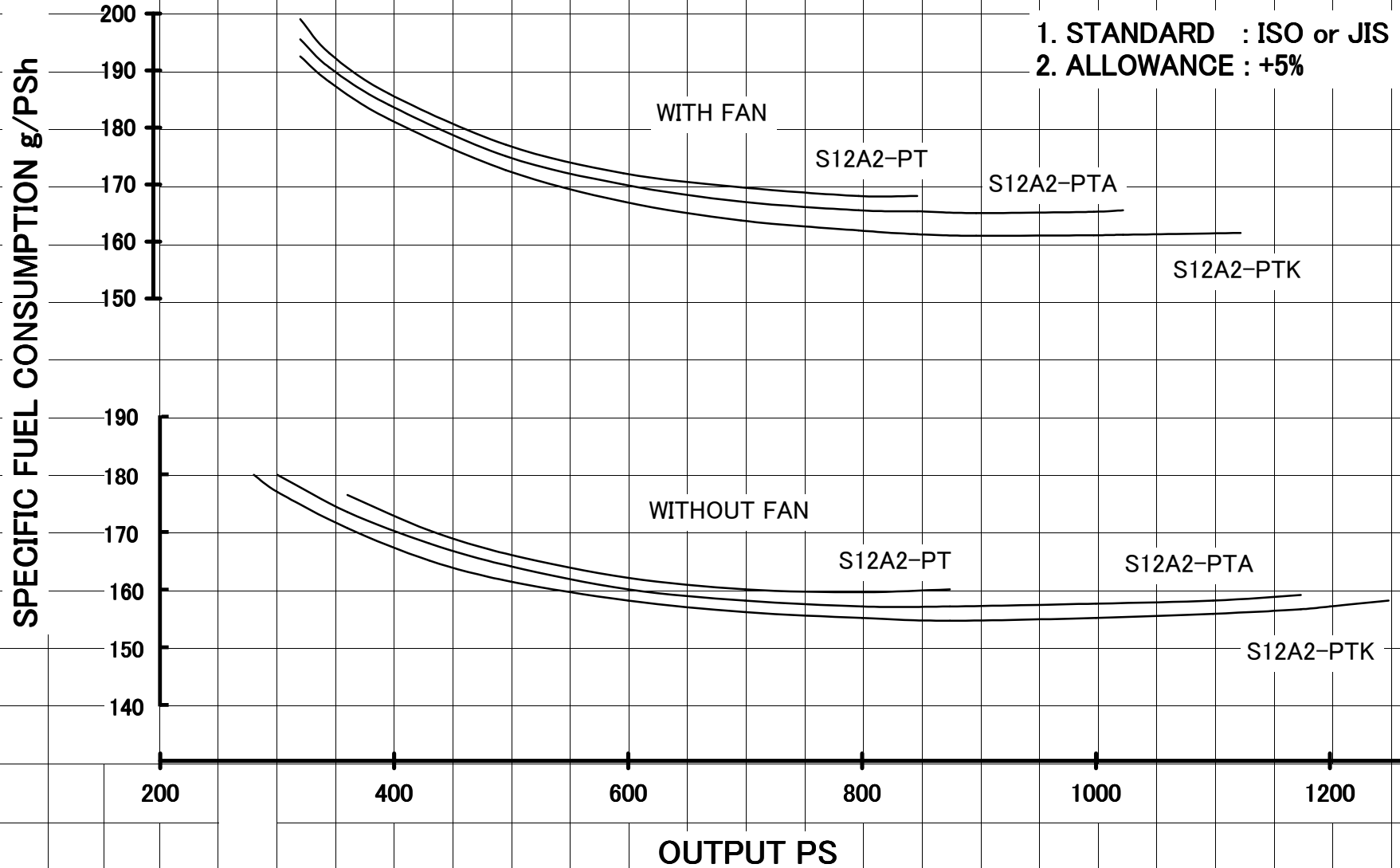

# SPECIFIC FUEL CONSUMPTION MODEL : S6R 1200rpm

- 1. STANDARD : ISO or JIS
- 2. ALLOWANCE : +5%

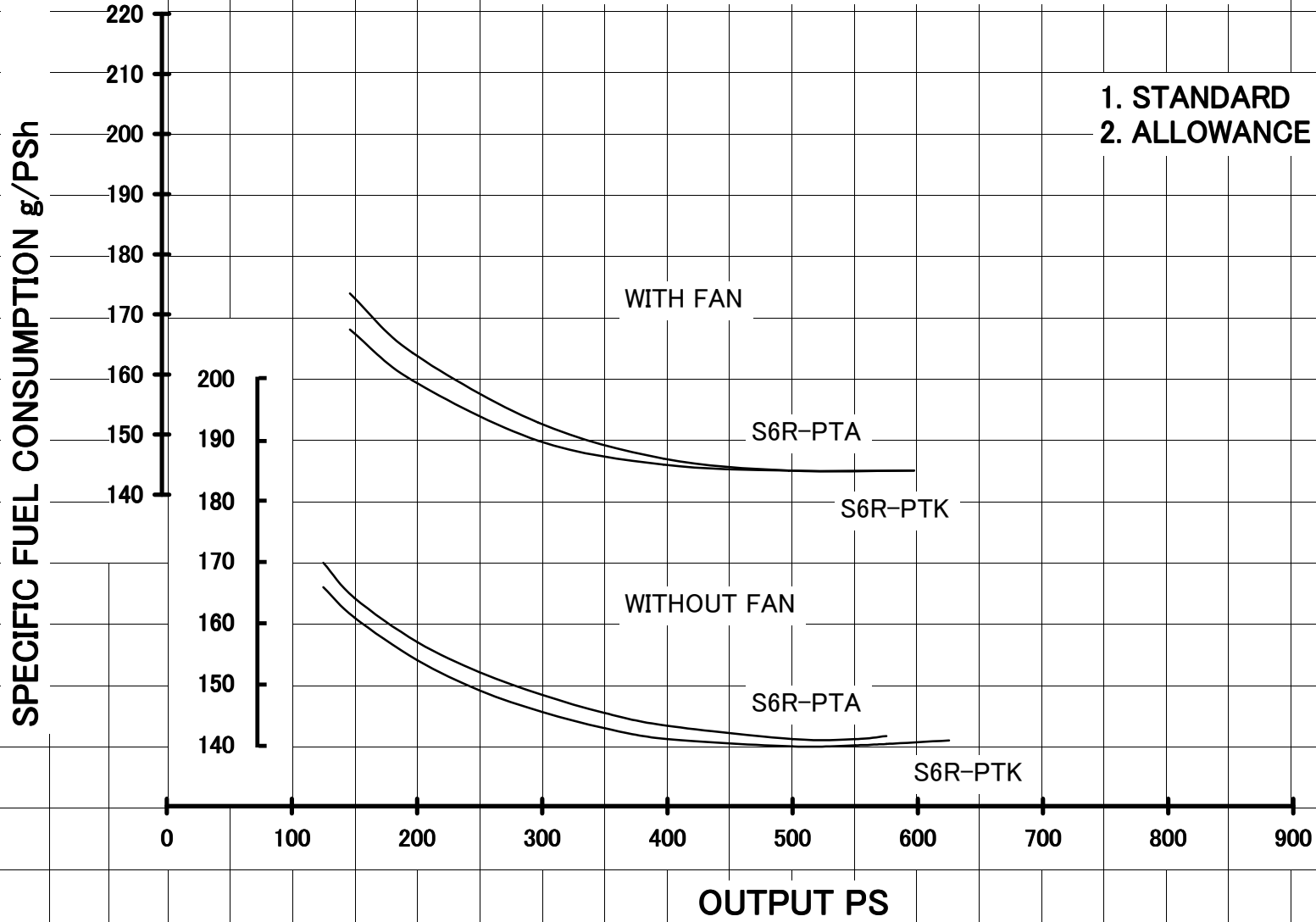

# SPECIFIC FUEL CONSUMPTION

MODEL : S6R 1500rpm

1. STANDARD : ISO or JIS

2. ALLOWANCE : +5%

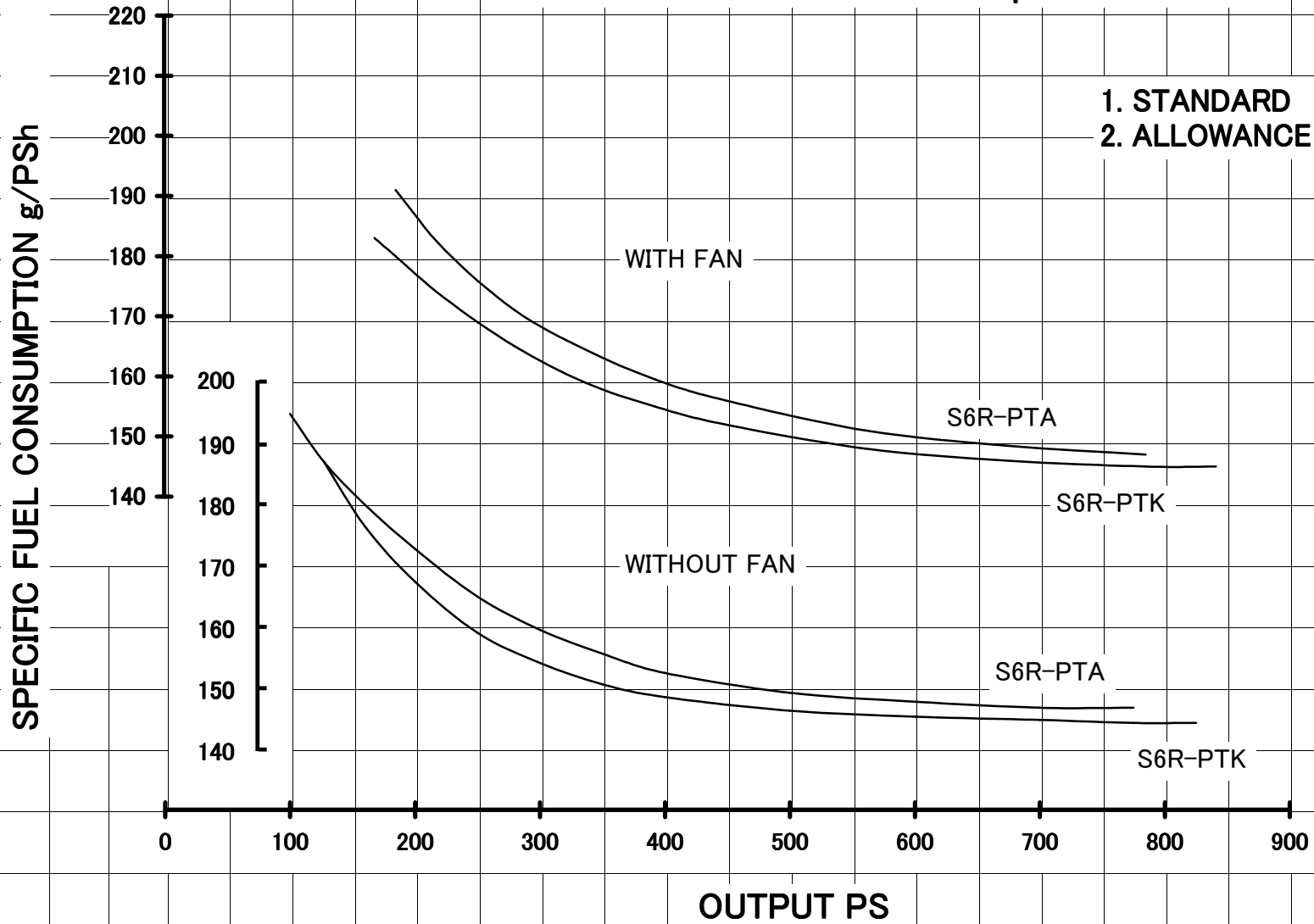



# SPECIFIC FUEL CONSUMPTION MODEL : S6R 1800rpm

- 1. STANDARD : ISO or JIS
- 2. ALLOWANCE : +5%

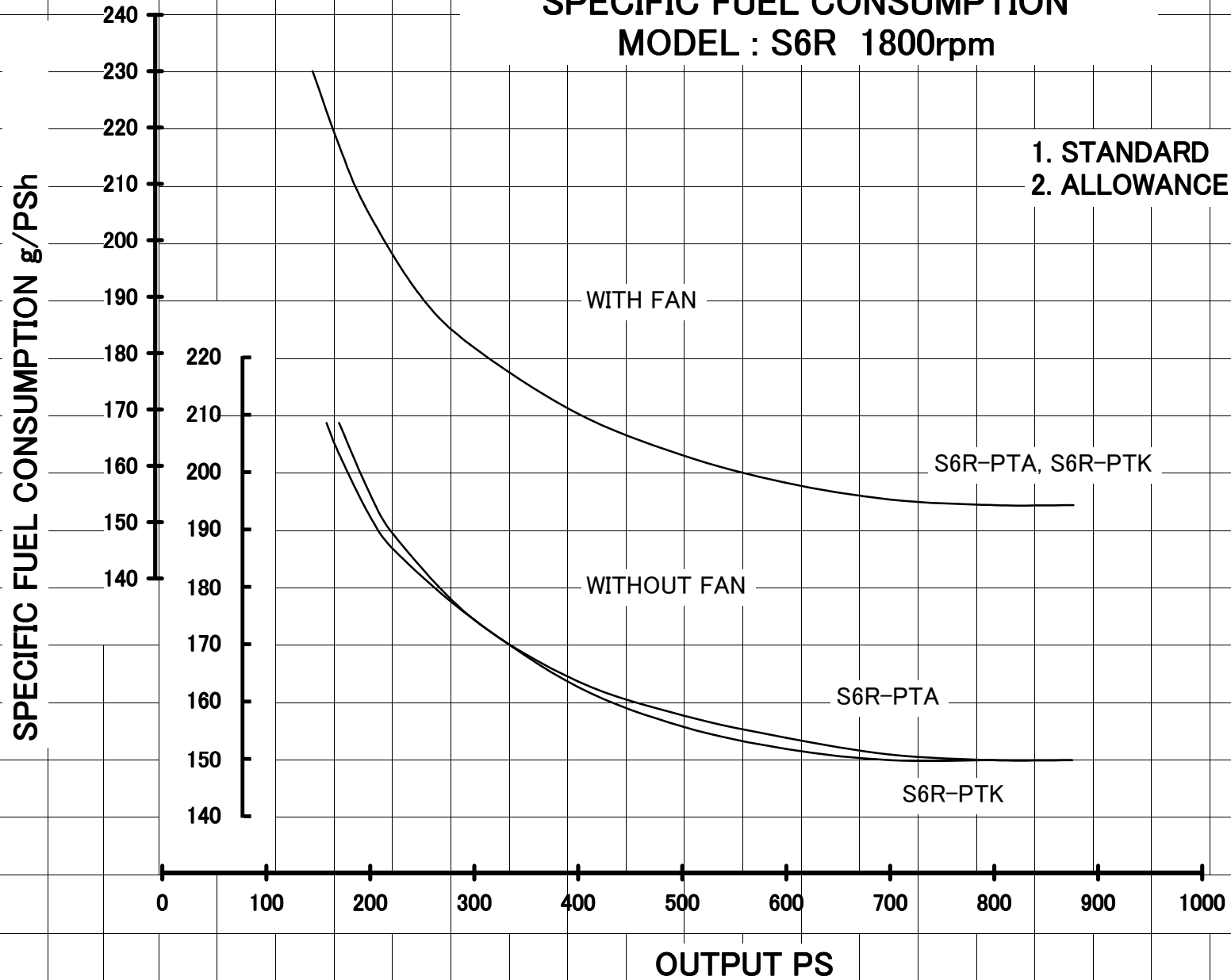

# SPECIFIC FUEL CONSUMPTION MODEL : S6R2 1000rpm

- 1. STANDARD : ISO or JIS
- 2. ALLOWANCE : +5%

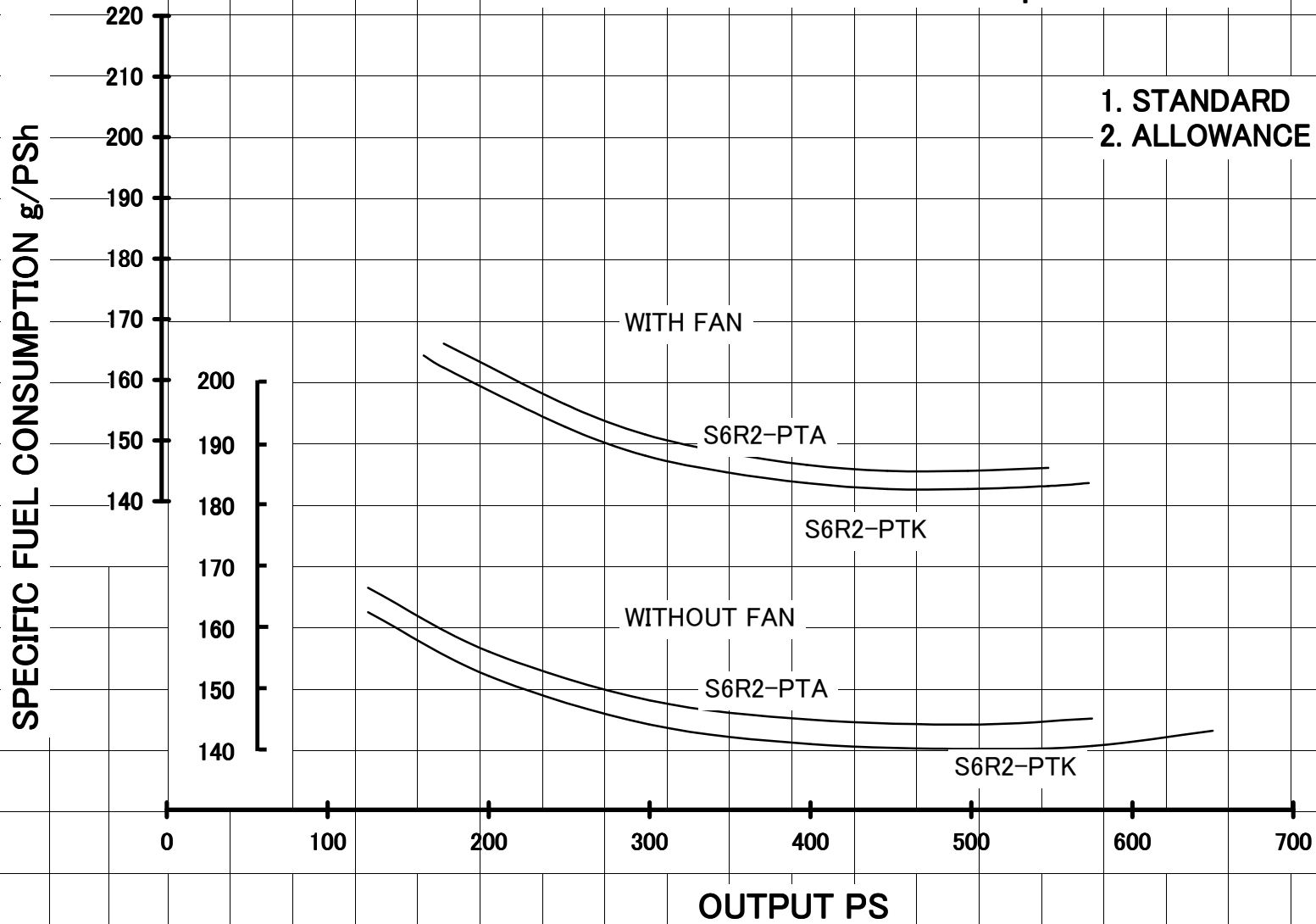

# SPECIFIC FUEL CONSUMPTION

MODEL : S6R2 1200rpm

1. STANDARD : ISO or JIS

2. ALLOWANCE : +5%

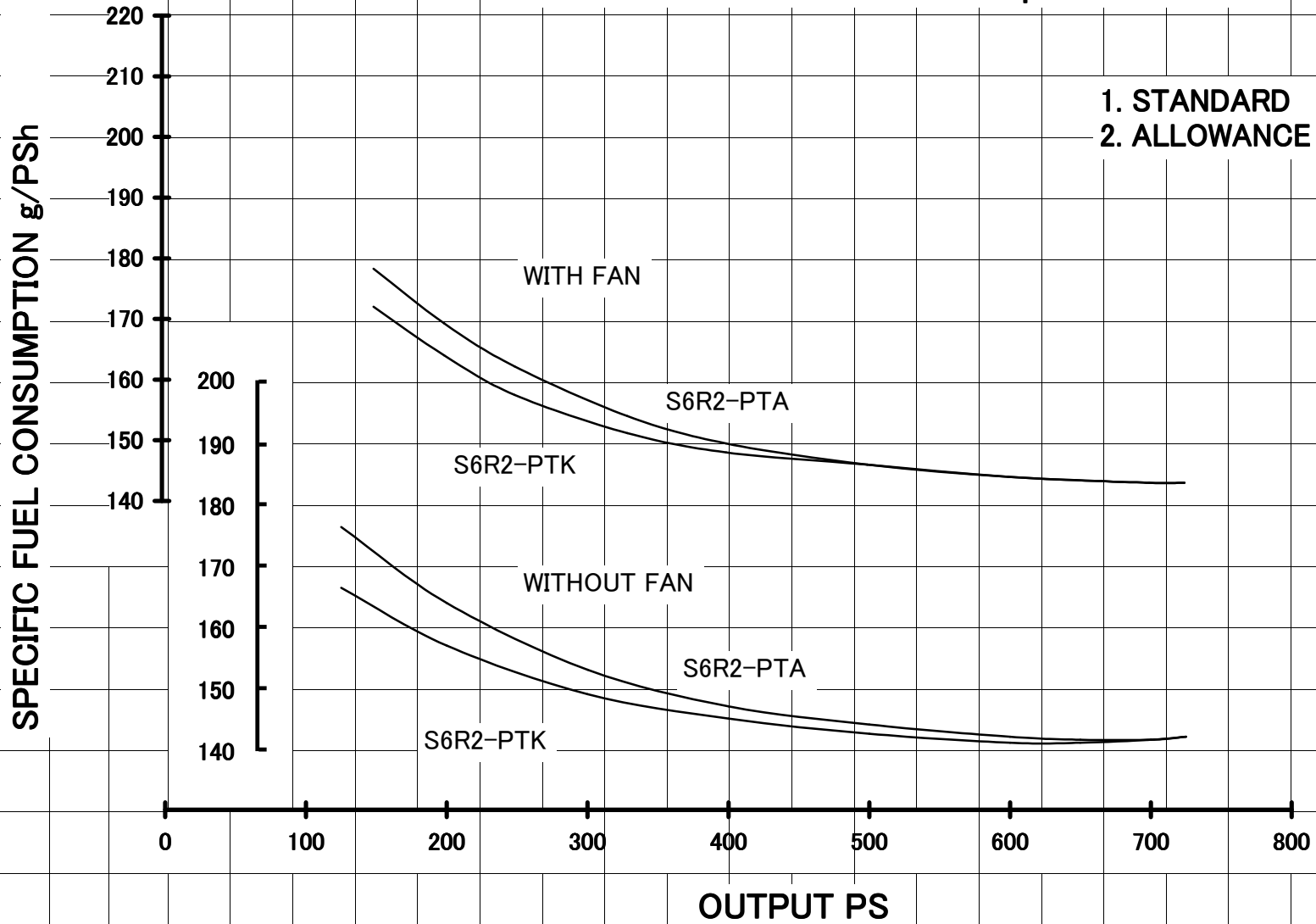

# SPECIFIC FUEL CONSUMPTION MODEL : S6R2 1500rpm

- 1. STANDARD : ISO or JIS
- 2. ALLOWANCE : +5%

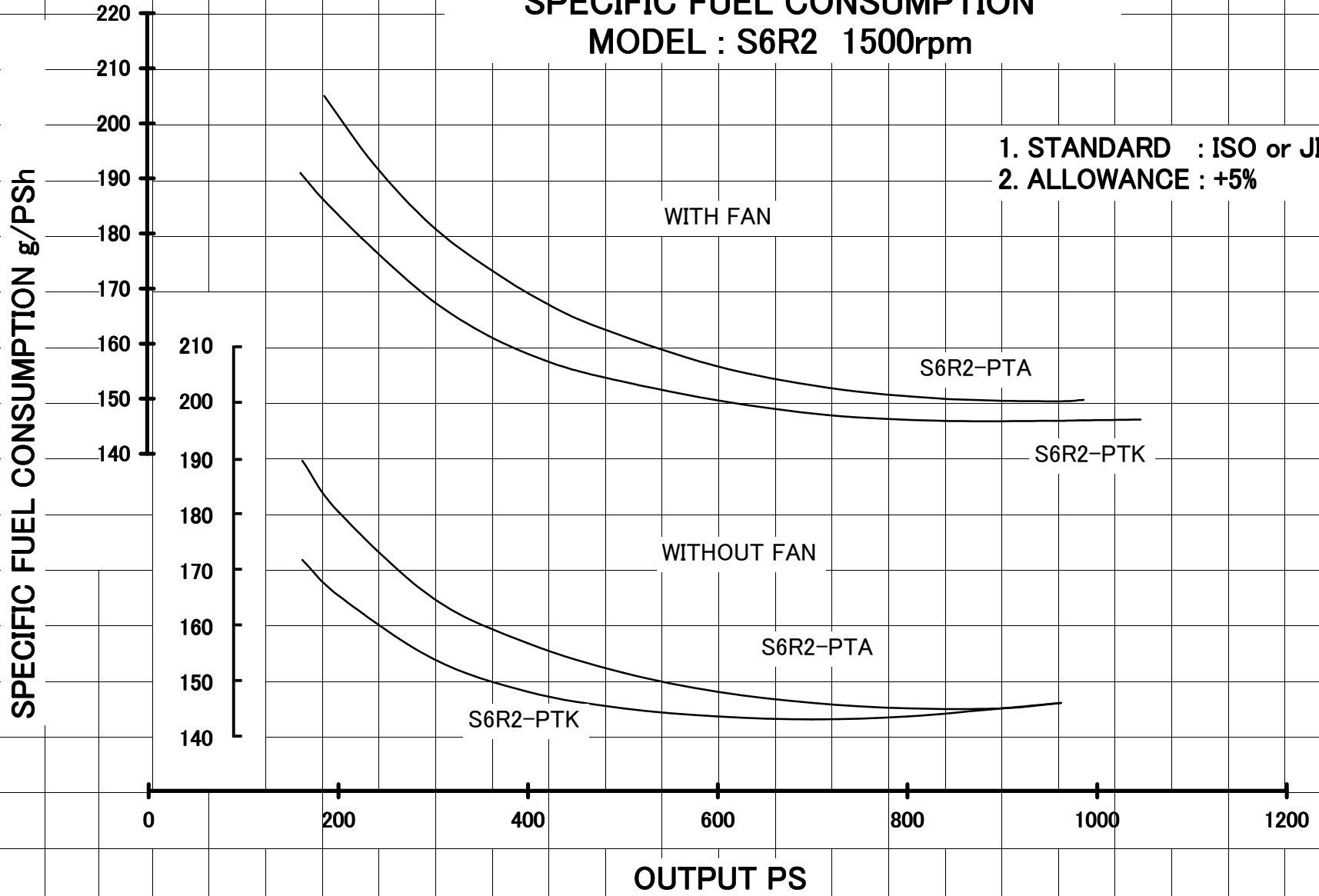

# SPECIFIC FUEL CONSUMPTION MODEL : S12R 1200rpm

- 1. STANDARD : ISO or JIS
- 2. ALLOWANCE : +5%

SPECIFIC FUEL CONSUMPTION g/PS<sub>h</sub>

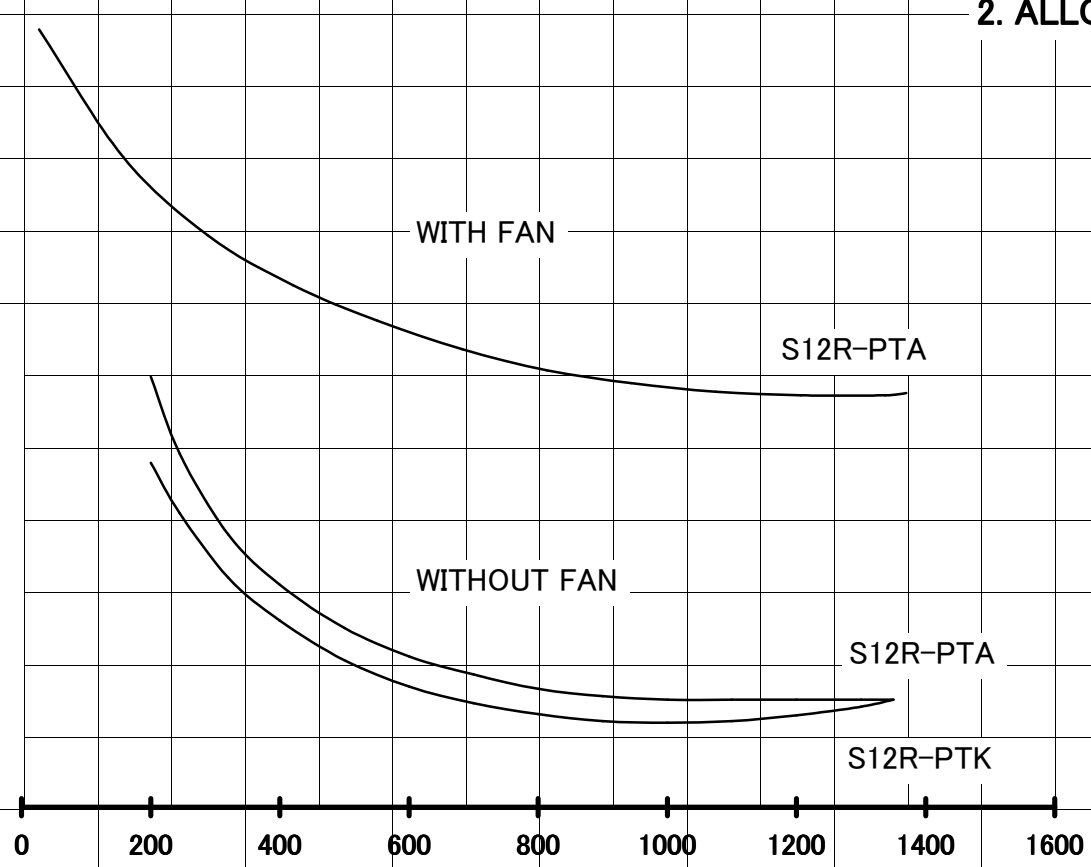
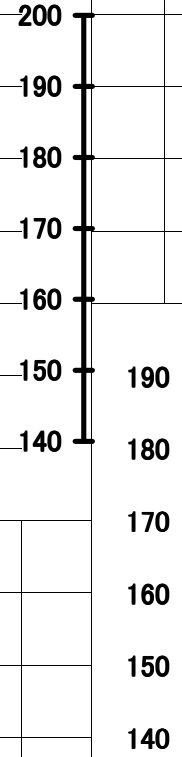

OUTPUT PS

# SPECIFIC FUEL CONSUMPTION MODEL : S12R 1500rpm

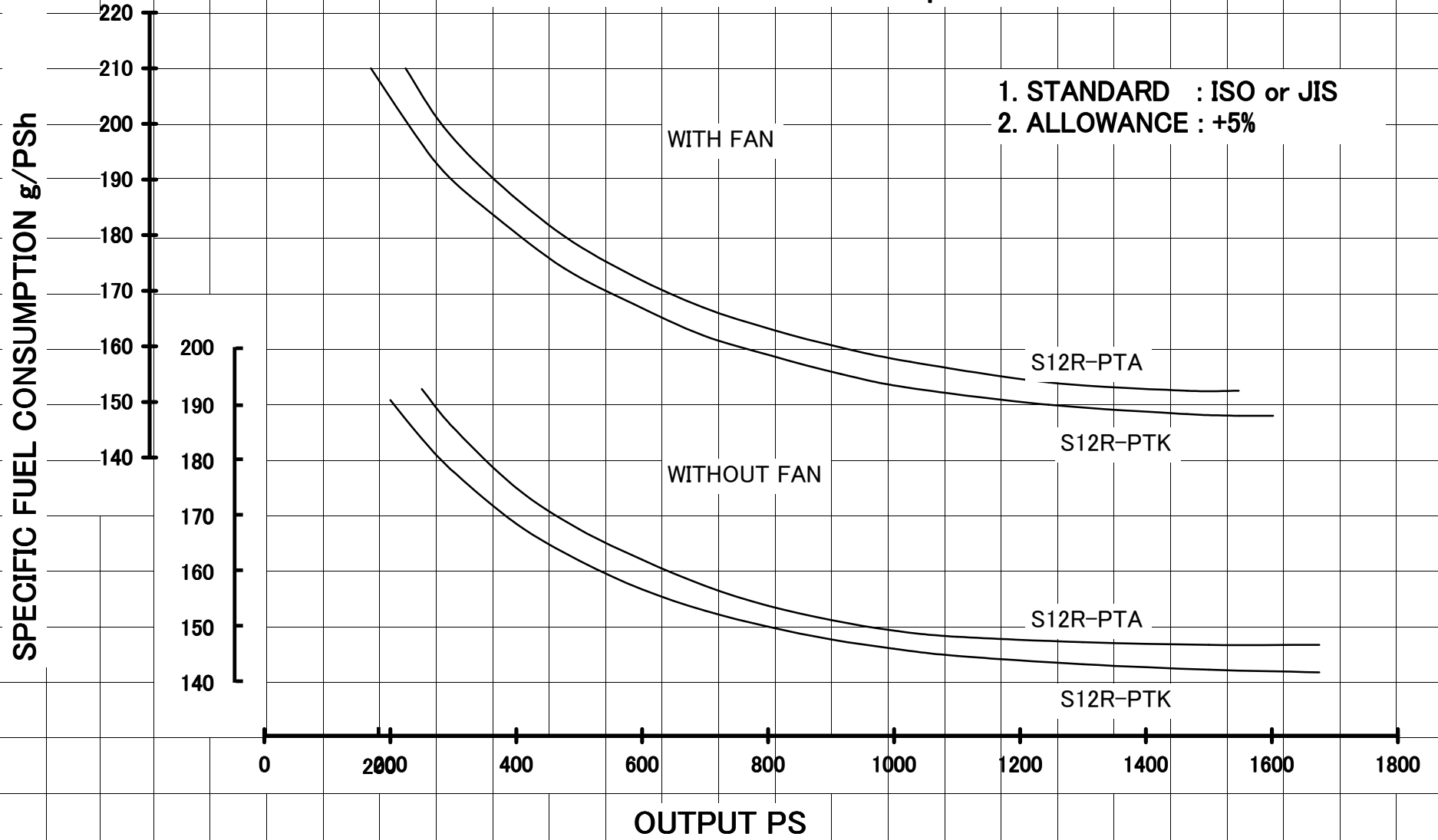

# SPECIFIC FUEL CONSUMPTION MODEL : S12R 1800rpm

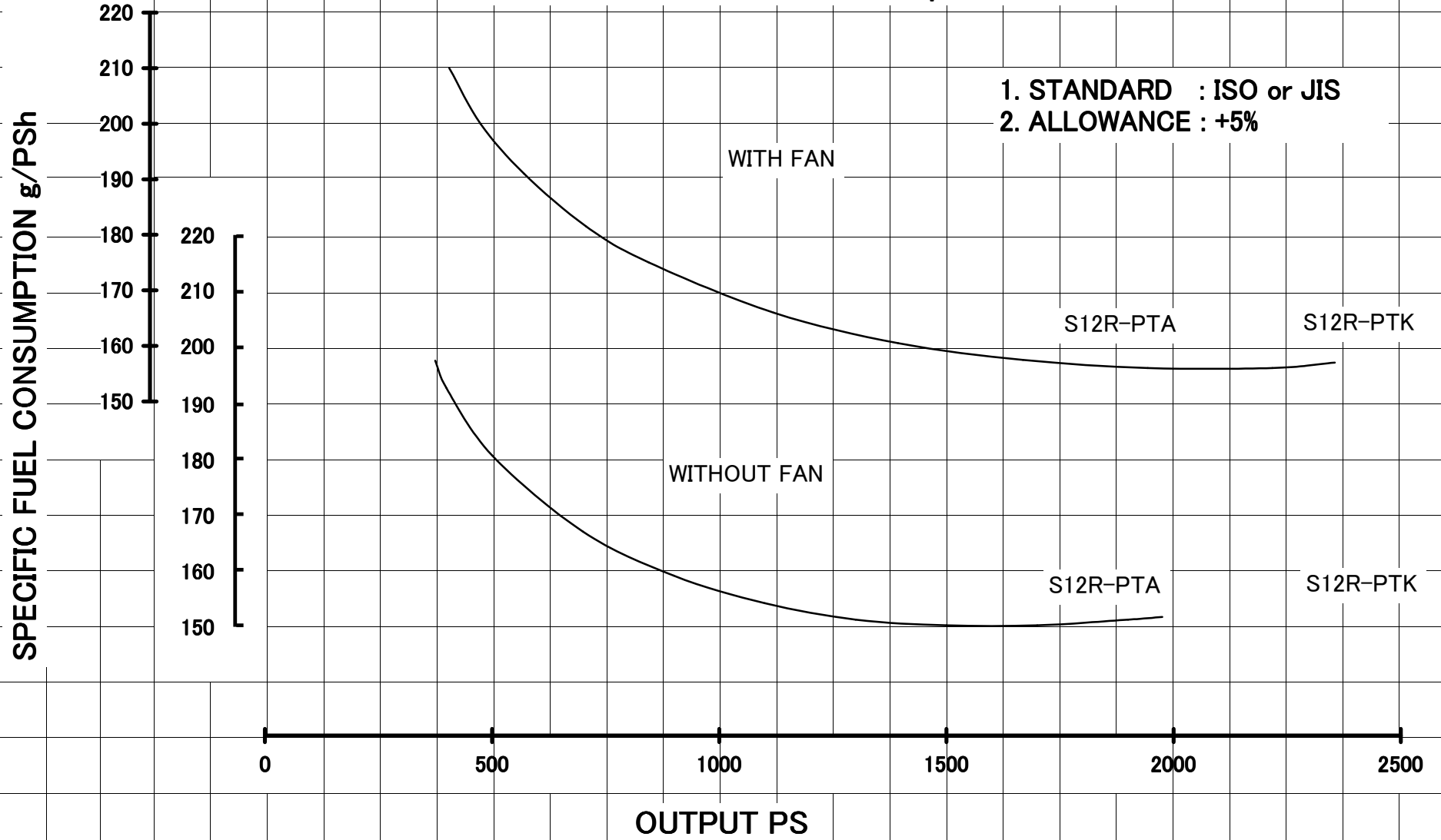

# SPECIFIC FUEL CONSUMPTION MODEL : S16R 1200rpm

- 1. STANDARD : ISO or JIS
- 2. ALLOWANCE : +5%

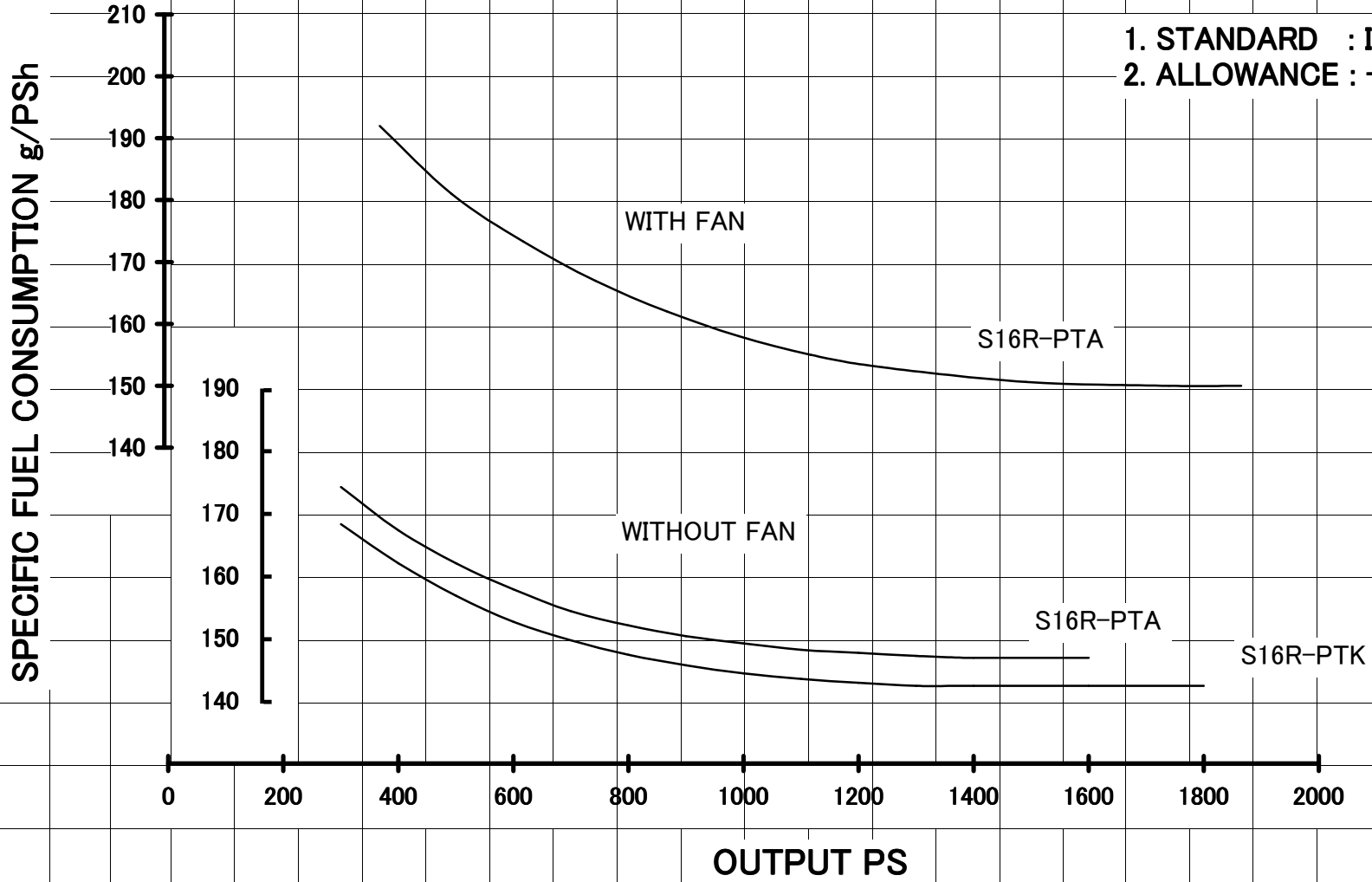



# SPECIFIC FUEL CONSUMPTION MODEL : S16R 1500rpm

- 1. STANDARD : ISO or JIS
- 2. ALLOWANCE : +5%

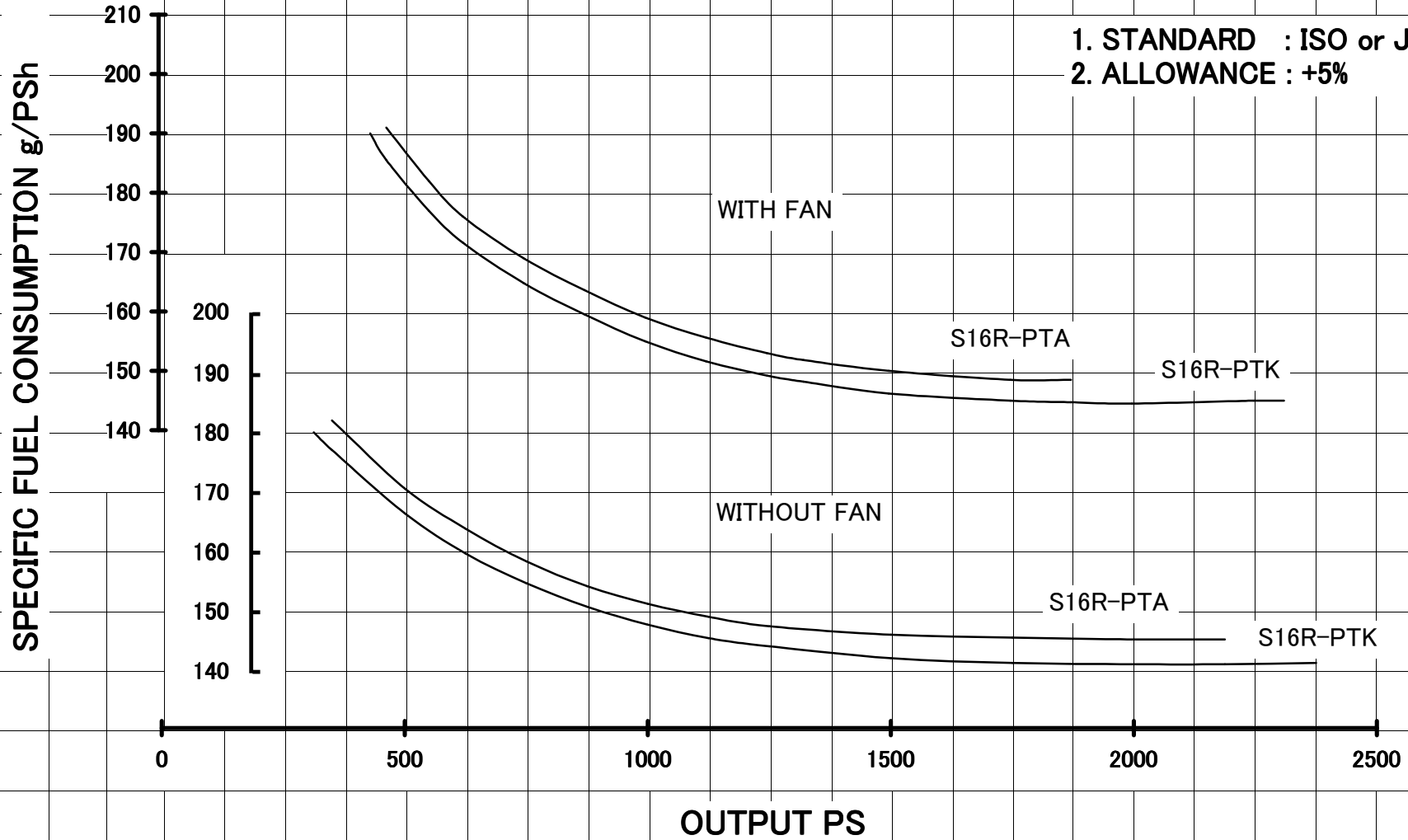

# SPECIFIC FUEL CONSUMPTION MODEL : S16R 1800rpm

- 1. STANDARD : ISO or JIS
- 2. ALLOWANCE : +5%

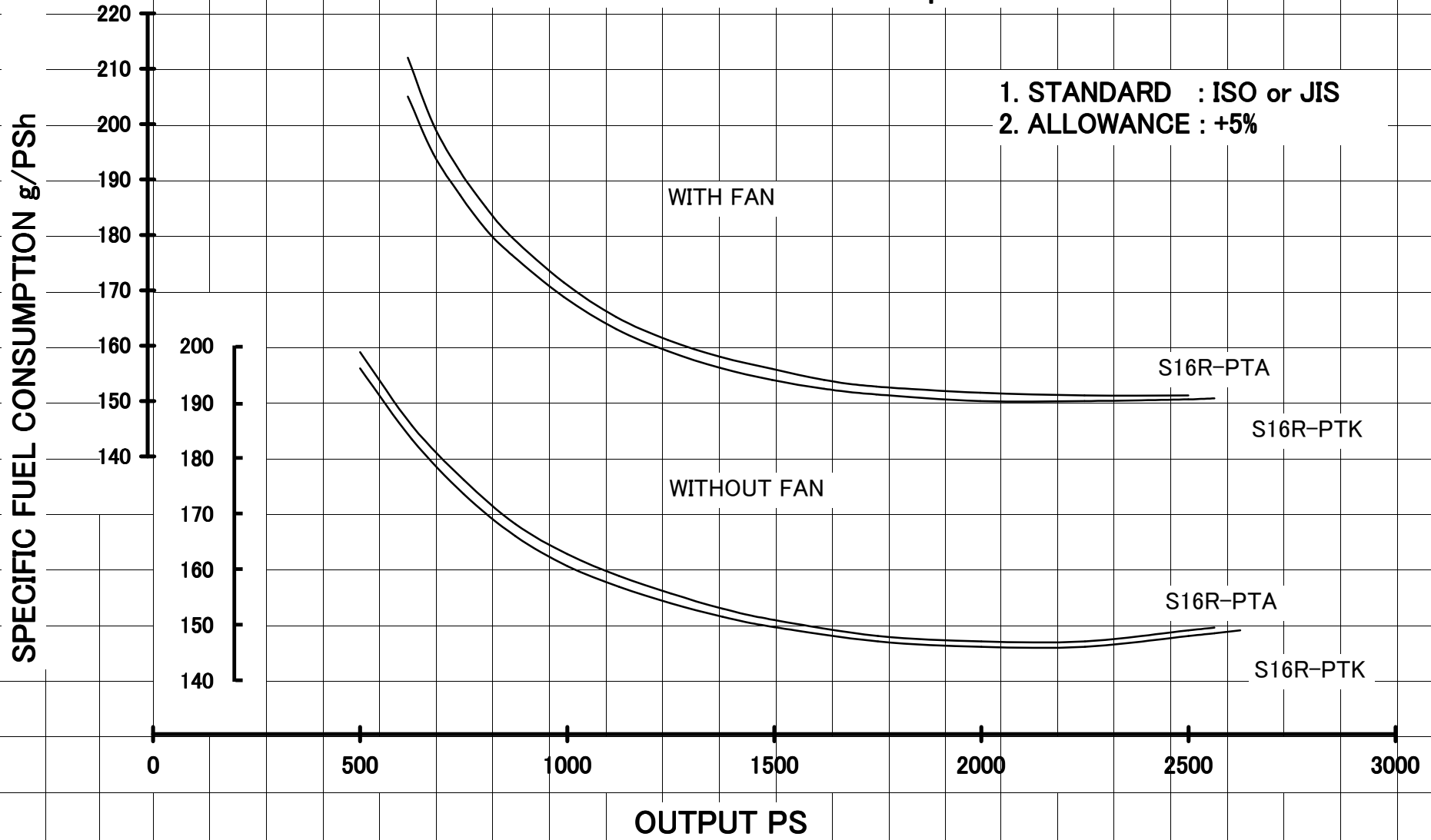

# SPECIFIC FUEL CONSUMPTION MODEL : S16R-2 1500rpm

- 1. STANDARD : ISO or JIS
- 2. ALLOWANCE : +5%
- 3. THIS INFORMATION IS SUBJECT TO CHANGE WITHOUT NOTICE

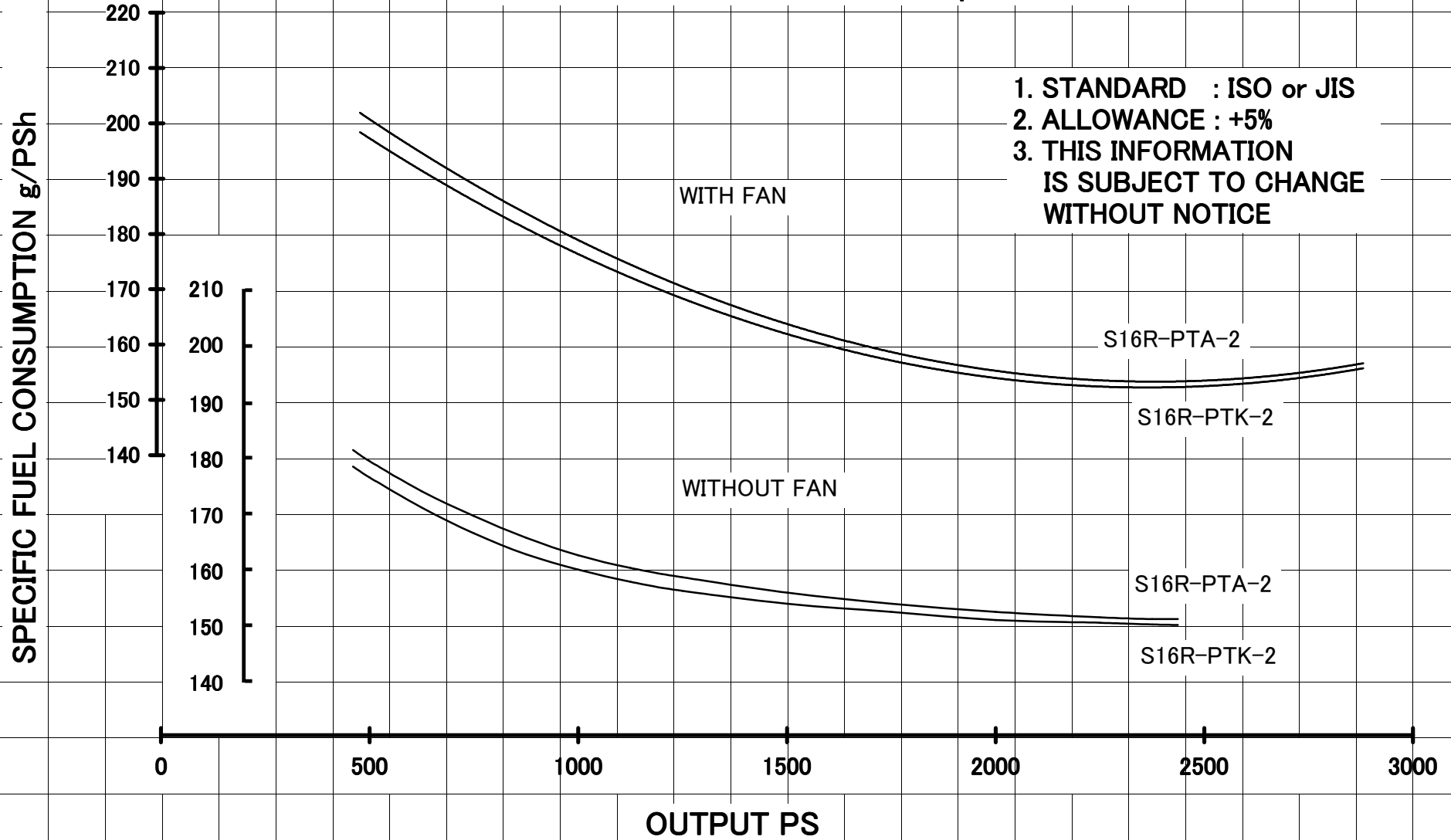

# SPECIFIC FUEL CONSUMPTION MODEL : S16R-2 1800rpm

- 1. STANDARD : ISO or JIS
- 2. ALLOWANCE : +5%
- 3. THIS INFORMATION IS SUBJECT TO CHANGE WITHOUT NOTICE

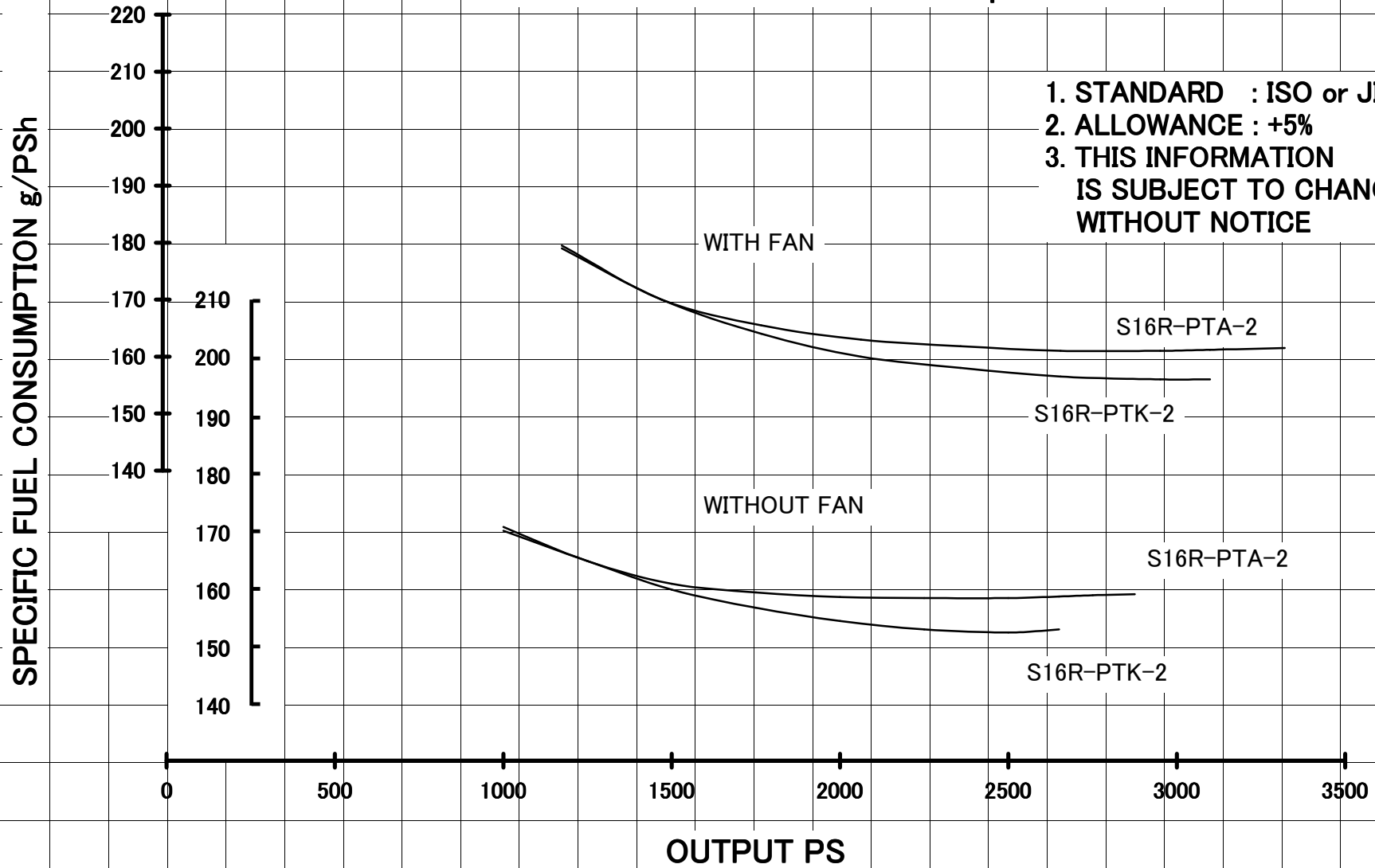

**SPECIFIC FUEL CONSUMPTION**  
**MODEL : S6R2-PTAA 1500rpm**

- 1. STANDARD : ISO or JIS
- 2. ALLOWANCE : +5%

**SPECIFIC FUEL CONSUMPTION g/PS<sub>h</sub>**

200  
190  
180  
170  
160  
150  
140

0 100 200 300 400 500 600 700 800 900 1000 1100

**OUTPUT PS**

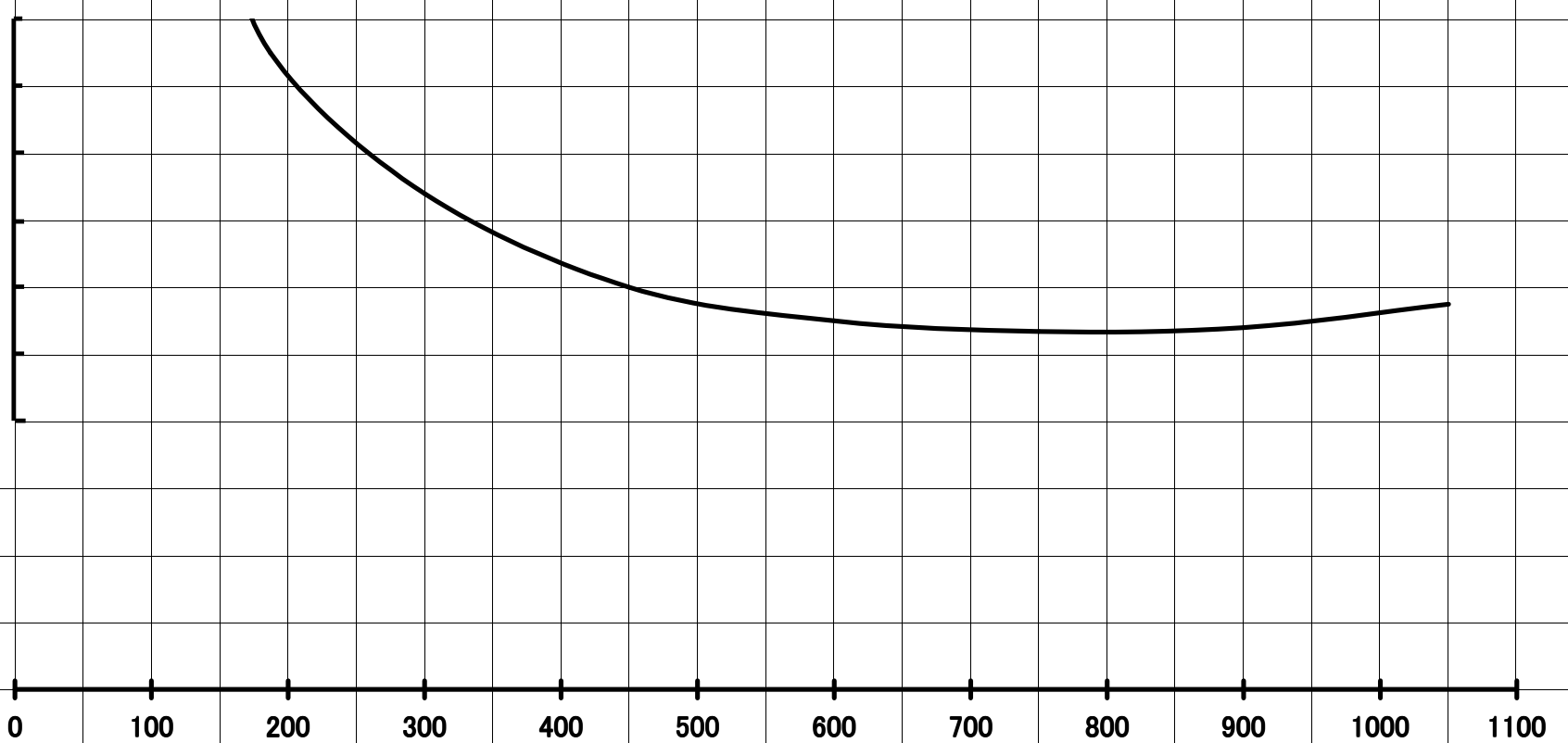

**SPECIFIC FUEL CONSUMPTION  
MODEL : S12H-PTA 1500rpm**

- 1. STANDARD : ISO or JIS
- 2. ALLOWANCE : +5%

SPECIFIC FUEL CONSUMPTION g/PS<sub>h</sub>

200  
190  
180  
170  
160  
150  
140

190  
180  
170  
160  
150  
140

0 200 400 600 800 1000 1200 1400 1600

OUTPUT PS

WITH FAN

WITHOUT FAN

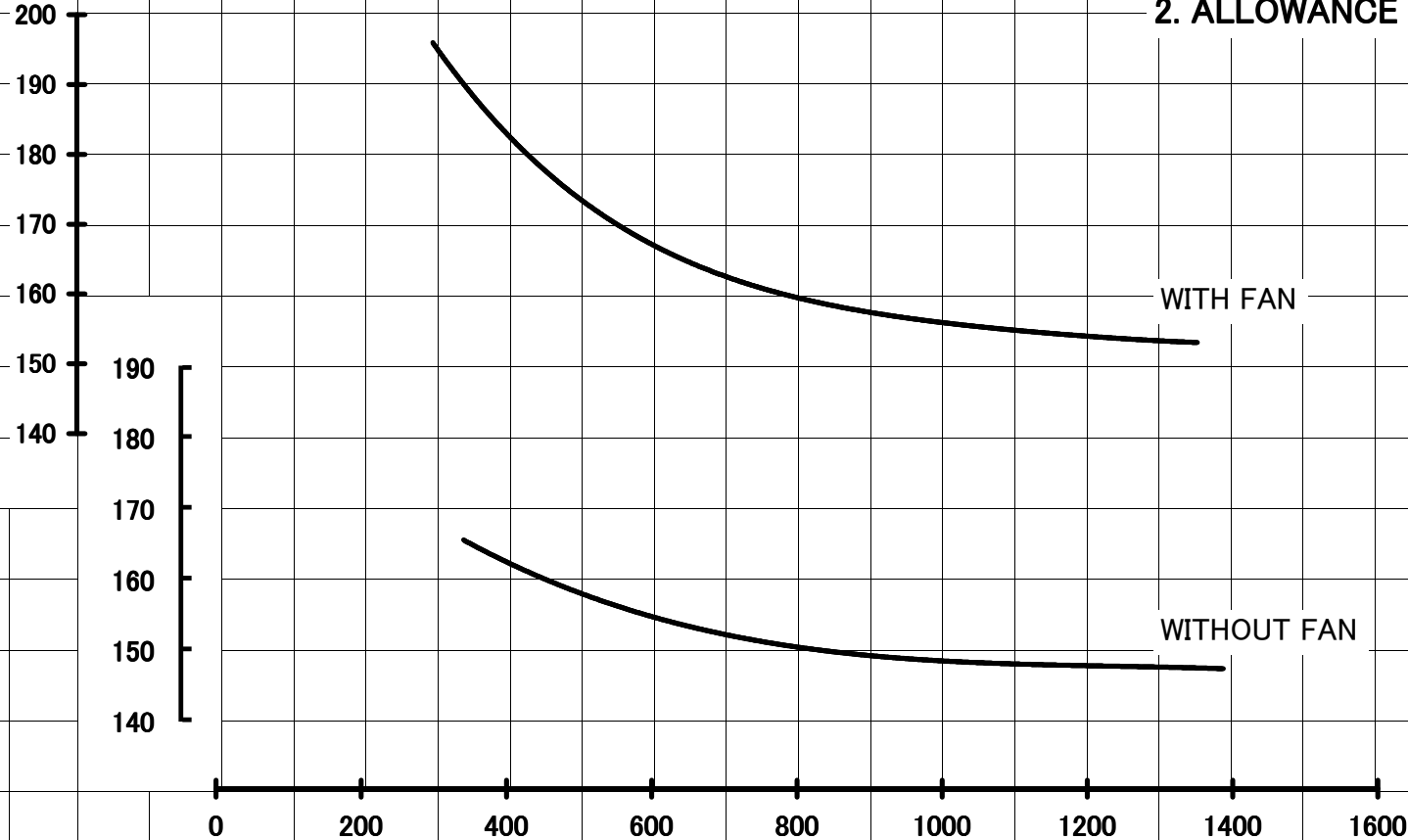

**SPECIFIC FUEL CONSUMPTION**  
**MODEL : S12H-PTA 1800rpm**

- 1. STANDARD : ISO or JIS
- 2. ALLOWANCE : +5%

**SPECIFIC FUEL CONSUMPTION g/PS<sub>h</sub>**

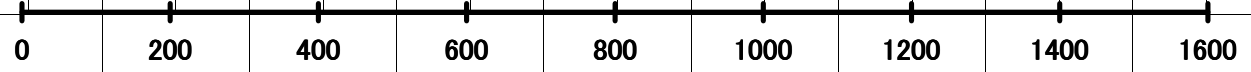
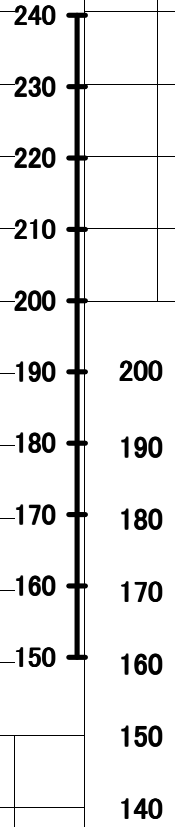

**OUTPUT PS**

WITH FAN

WITHOUT FAN

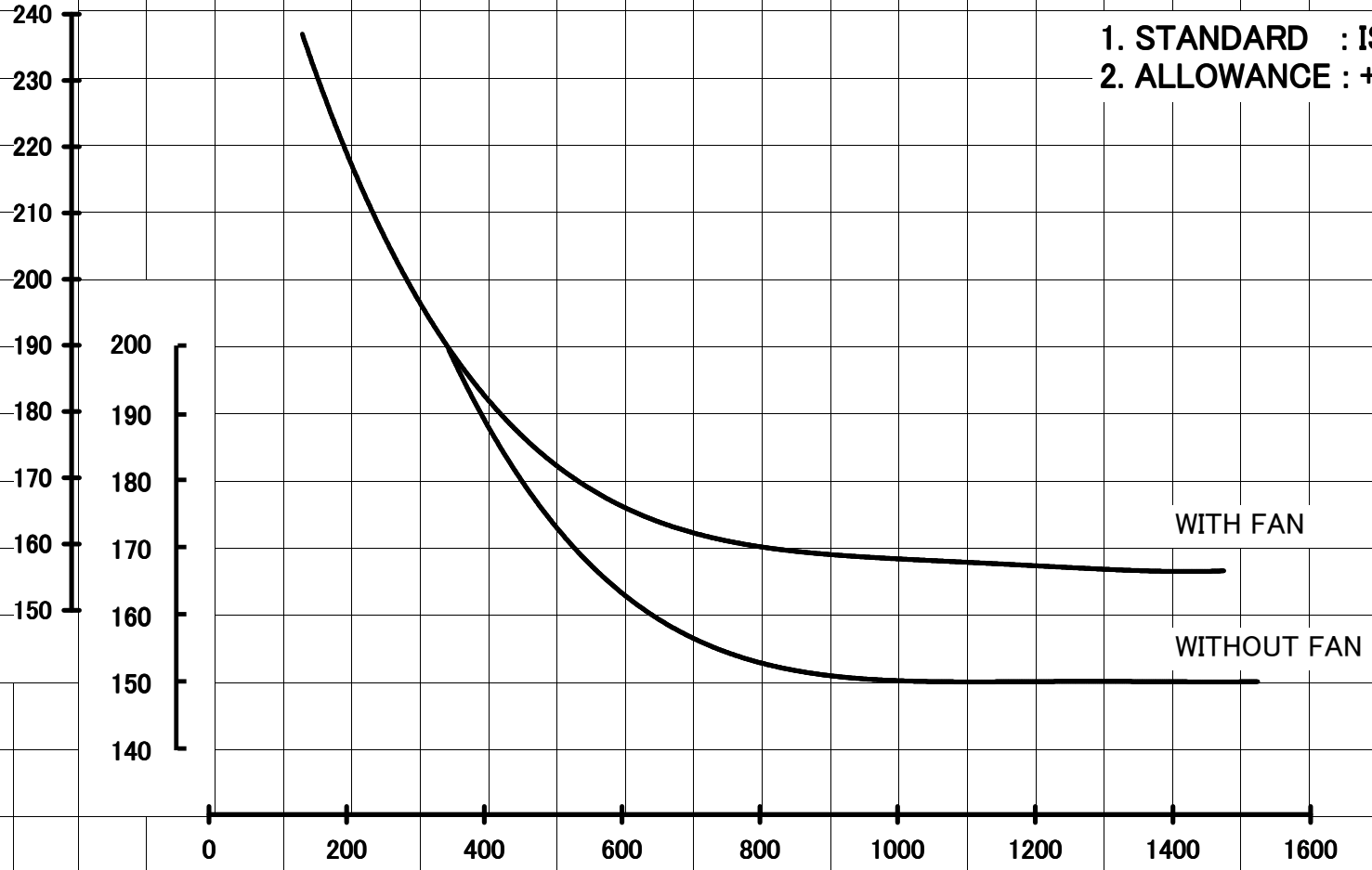

# SPECIFIC FUEL CONSUMPTION MODEL : S12R-PTAA2

- 1. STANDARD : ISO or JIS
- 2. ALLOWANCE : +5%

SPECIFIC FUEL CONSUMPTION g/PS<sub>h</sub>

200  
190  
180  
170  
160  
150  
140

0 200 400 600 800 1000 1200 1400 1600 1800 2000 2200

OUTPUT PS

1500 rpm

1800 rpm

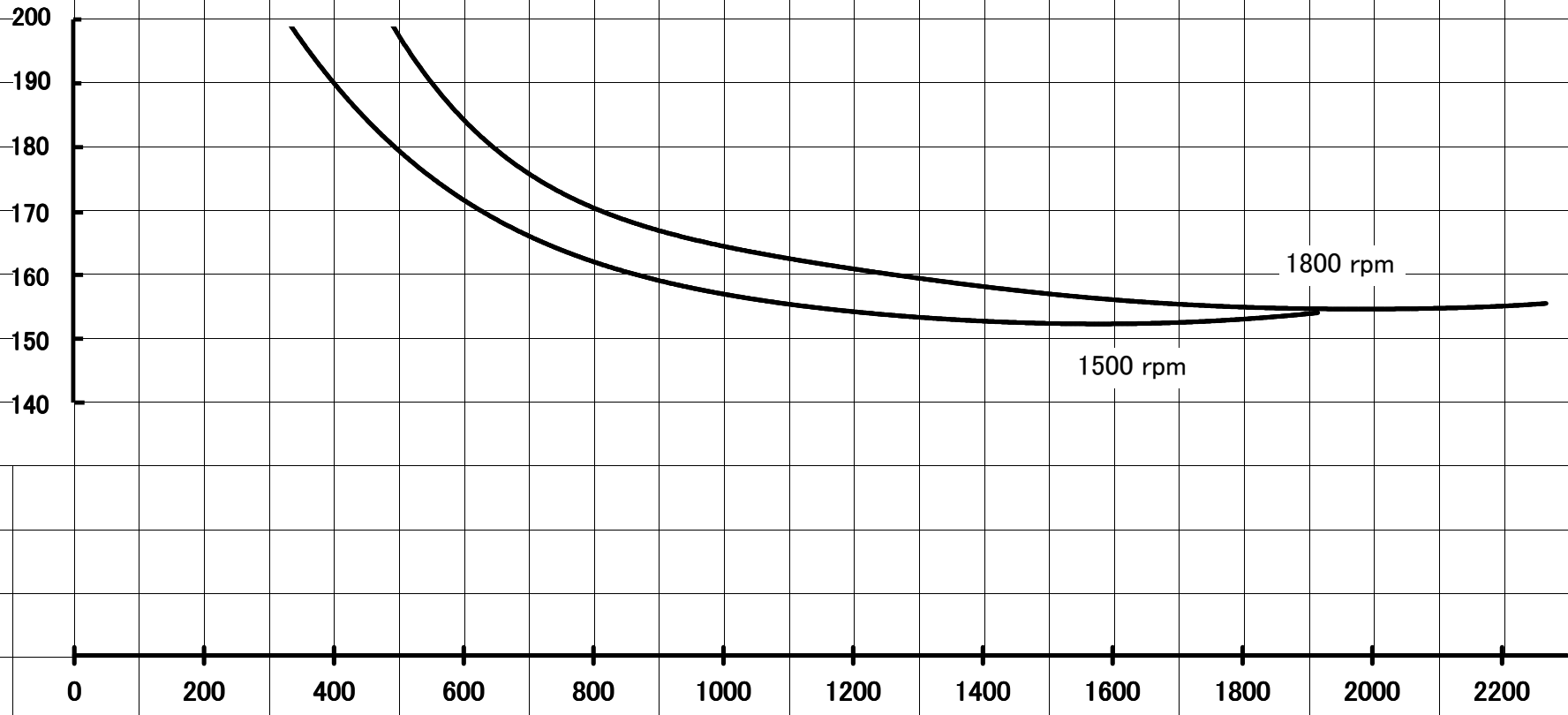



# SPECIFIC FUEL CONSUMPTION MODEL : S16R-PTAA2

- 1. STANDARD : ISO or JIS
- 2. ALLOWANCE : +5%

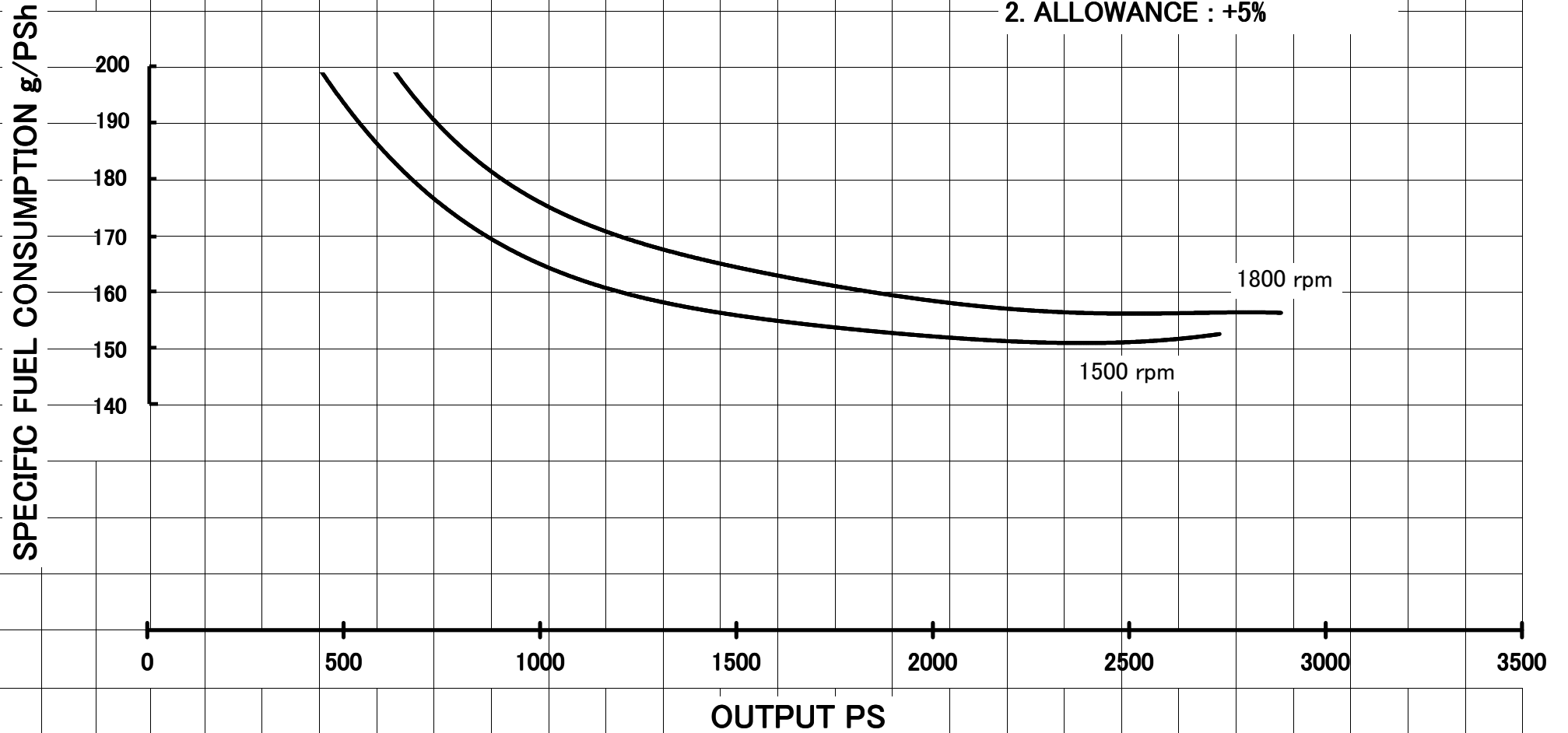

# SPECIFIC FUEL CONSUMPTION MODEL : S12R-2 1500rpm

- 1. STANDARD : ISO or JIS
- 2. ALLOWANCE : +5%

SPECIFIC FUEL CONSUMPTION g/PS<sub>h</sub>

220  
210  
200  
190  
180  
170  
160  
150  
140

200  
190  
180  
170  
160  
150  
140

0 200 500 1000 1500 2000 2100

OUTPUT PS

WITH FAN

WITHOUT FAN

PTA2

PTK2

PTA2

PTK2

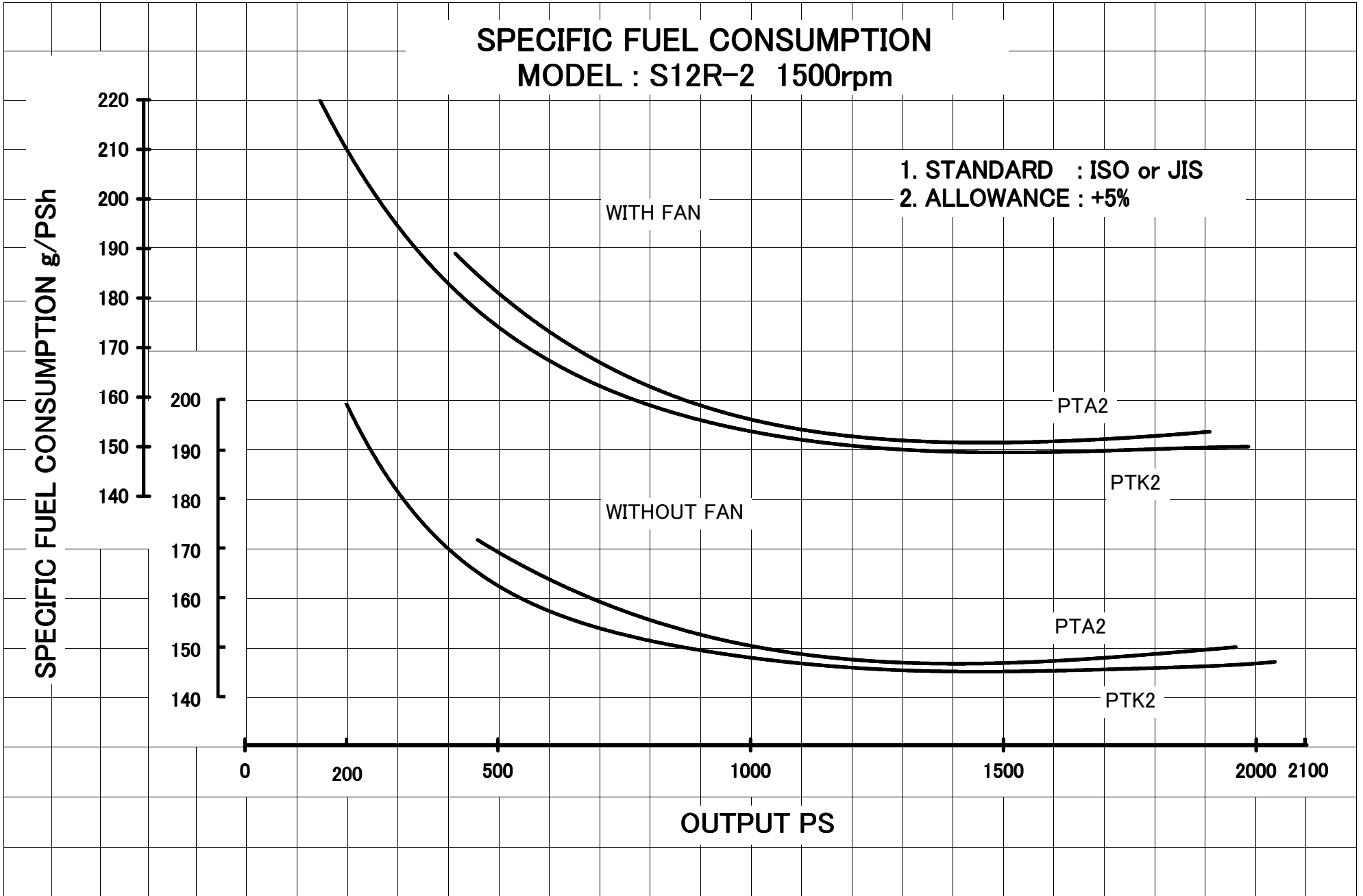

# SPECIFIC FUEL CONSUMPTION MODEL : S12R-2 1800rpm

- 1. STANDARD : ISO or JIS
- 2. ALLOWANCE : +5%

