

mitsubishi S6A3-PTA

Click on the headlines below to get redirected to the respective sections in this document.

[GA drawing](#)

[Technical data](#)

[Elastic data](#)

[Exhaust gas emission](#)

[Fuel consumption](#)

Power House AB

Talattagatan 10, SE-426 76 Västra Frölunda, Sweden

Tel: +46 31 762 56 00, info@powerhouse.se

www.powerhouse.se

NO.	PARTS NAME	SIZE	REFERENCE
1	FLYWHEEL & HOUSING	35A96-21001	
2	OIL PRESS. GAGE UNIT JOINT	Rc1/8	35A96-01011
3	OIL PRESS. SWITCH JOINT	Rc1/8	↑
4	OIL PRESS. SWITCH JOINT	Rc1/8	
5	THERMOSWITCH JOINT	M16x1.5	
6	THERMOSWITCH JOINT	Rc1/2	
7	THERMOMETER UNIT JOINT	Rc1/2	
8	OIL PAN (A) JOINT	M16x1.5	
9	OIL PAN (B) JOINT	M20x1.5	
10	OIL PAN (C) JOINT		
11	AIR PRESS. GAGE JOINT	Rc1/8	
12	PICKUP JOINT	UNF5/8-18	
13	FUEL INLET PIPE JOINT	Rc1/2	↓
14	FUEL RETURN PIPE JOINT	Rc1/2	35A96-01011
15	FUEL FILTER		
16	FUEL INJECTION PUMP		
17	GOVERNOR		
18	OIL LEVEL GAGE		
19	OIL FILTER		
20	OIL BY-PASS ALARM SWITCH		35A96-01011
21	BREATHER & OIL FILLER		
22	WATER INLET JOINT	65A	35A96-01011
23	WATER OUTLET JOINT	φ60.5	35A96-01011
24	WATER DRAIN COCK		
25	STOP SOLENOID		
26	EXHAUST FLANGE	200A	
27	THERMOMETER, EX. JOINT	G3/4	35A96-01011

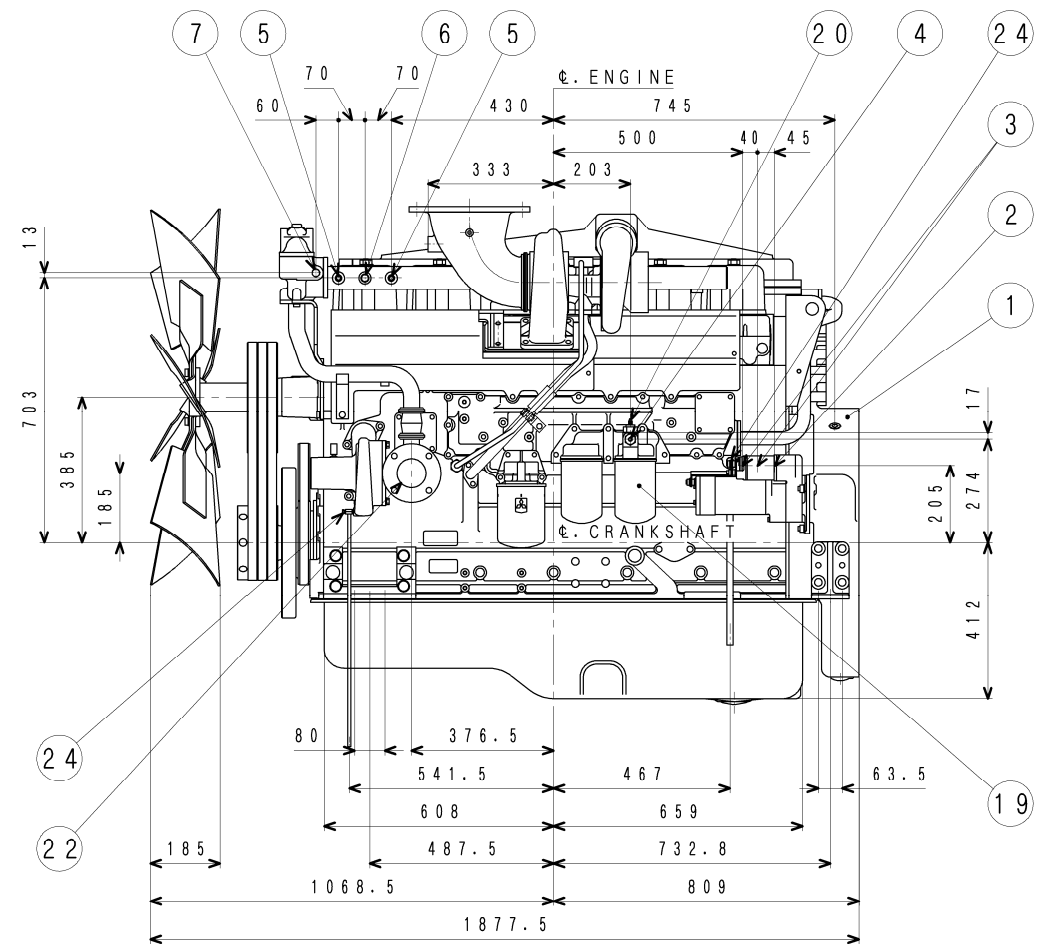
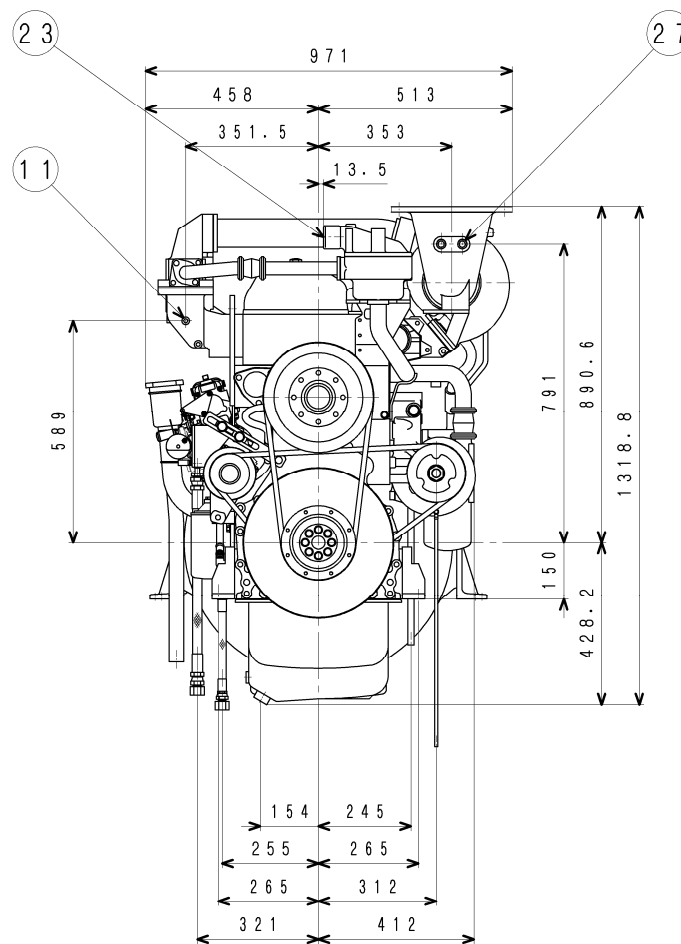
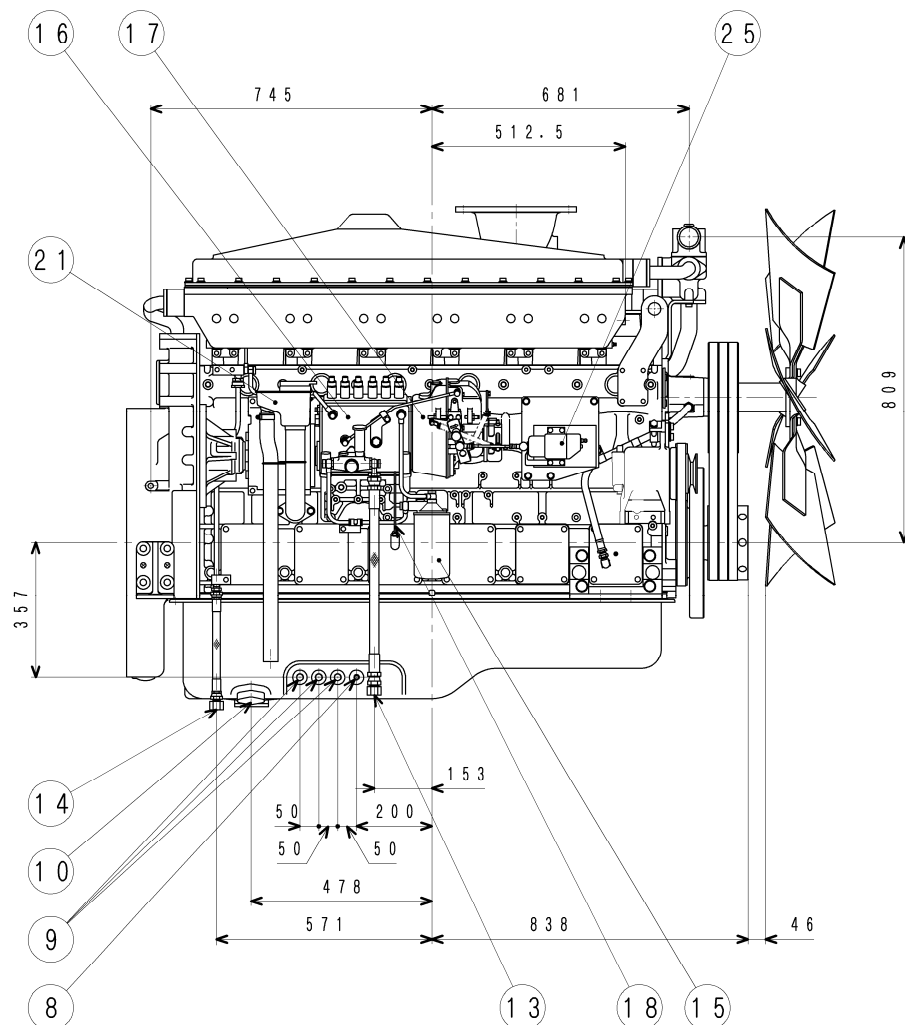
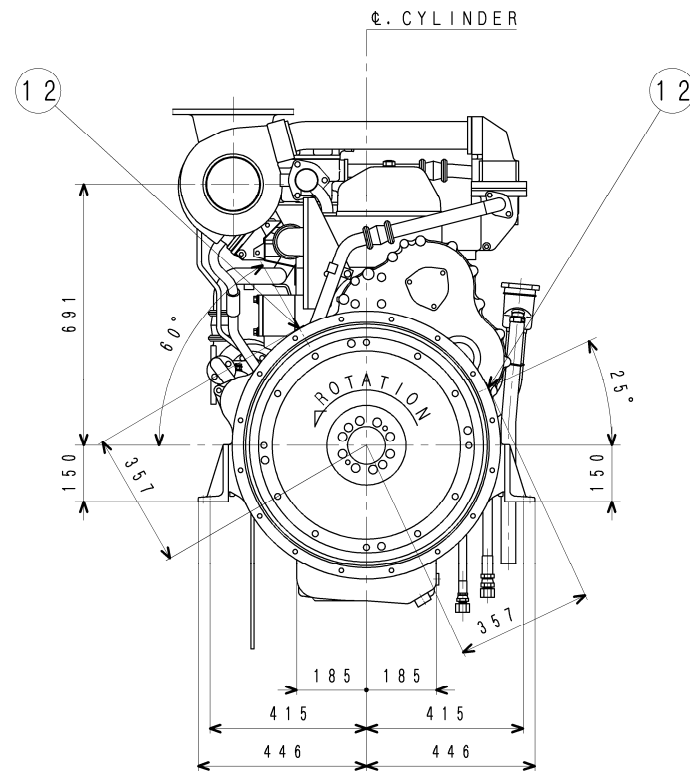
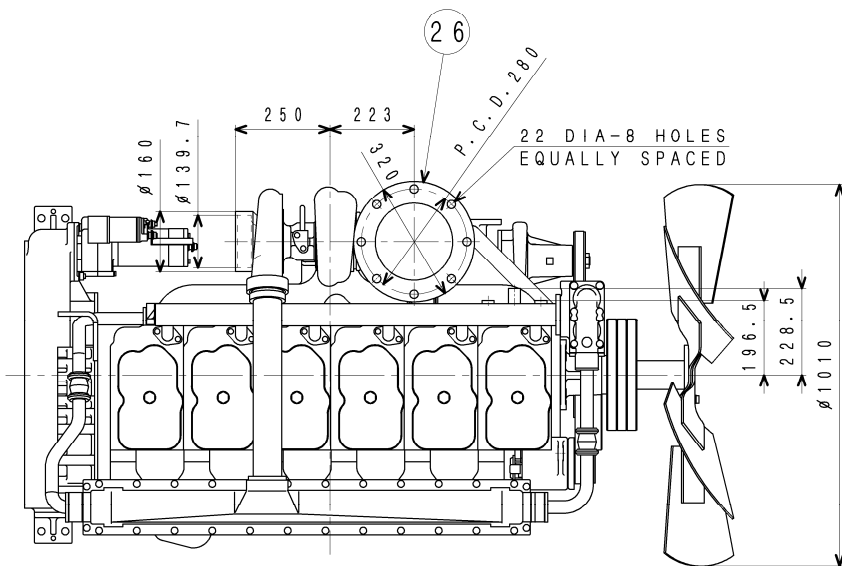

(3) RSUV-DメカGOV. 装備。
 (2) 三菱TD10L/1500min⁻¹, 1800min⁻¹共用ターボ装備。
 注記 (1) 本図は、S6A3-PTA/ファン付非常用発電装置用標準単体図である。

承認 APPD	仁尾	検図 CHK	松福 下田	製図 DWH	谷齊 戸藤
CHG	ED-NO	DATE	CHK	3RD ANGLE PROJECTION	
2	4590-E574'08.6.2	齊藤		尺規 SCALE	
1	4590-9743'03.2.5	福田		:	
S6A3-PTA DIESEL ENGINE					
三菱重工業株式会社 汎用機・特車事業本部					
MITSUBISHI HEAVY INDUSTRIES, LTD. GENERAL MACHINERY & SPECIAL VEHICLE HEADQUARTERS.					
図面番号 35A96-00201					
DRAWING NO. 35A96-00201					
3 新 図 4 欠 図 5 補 正 品 6 他 社 製 品 7 組 立 品 8 特 種 品 9 特 許 品 10 特 許 品 11 特 許 品 12 特 許 品 13 特 許 品 14 特 許 品 15 特 許 品 16 特 許 品 17 特 許 品 18 特 許 品 19 特 許 品 20 特 許 品 21 特 許 品 22 特 許 品 23 特 許 品 24 特 許 品 25 特 許 品 26 特 許 品 27 特 許 品					

旧引
汎特
2008
11.4

FULL-CAD



**MITSUBISHI DIESEL ENGINE
TECHNICAL INFORMATION**

ITEM NO.	T0212-0001E Rev.2 (1/4)
DATE	January, 2014

Specification Sheets of S6A3-PTA Engine

Specification Sheets of S6A3-PTA Engine are enclosed herein.

Revision	First Edition : September, 2007 (T13-0302-E Jun.99)	Engine Engineering Department High Speed Engine Designing Section		
	Rev.1 : Mar., 2013			
	Rev.2 : Jan., 2014	Approved by	Checked by	Drawn by
		T.HASHIGUCHI	T.OGURA	K.NAKAMURA

GENERAL ENGINE DATA

Type	4-Cycle, Water Cooled	
Aspiration	Turbo-Charged, After Cooler (Jacket water to Cooler)	
Cylinder Arrangement	Inline	
No. of Cylinders	6	
Bore mm(in.)	150	(5.91)
Stroke mm(in.)	175	(6.89)
Displacement liter(in ³)	18.56	(1133)
Compression Ratio	14.5:1	
Dry Weight - Engine only - kg(lb)	1800	(3969)
Wet Weight - Engine only - kg(lb)	1910	(4212)

PERFORMANCE DATA

Steady State Speed Stability Band at any Constant Load

Mechanical - %	±0.5	
Hydraulic (std.) or Electric Governor - %	±0.25 or better	
Maximum Overspeed Capacity - rpm	2300	
Moment of inertia of Rotating Components - kgf·m ² (lbf·ft ²)	32.09	(761.6)
(Includes Std. Flywheel)		
Cyclic Speed Variation with Flywheel at 1800rpm	1/180	
1500rpm	1/120	

ENGINE MOUNTING

Maximum Bending Moment at Rear Face of Flywheel Housing - kgf·m(lbf·ft)	200	(1447)
---	-----	--------

AIR INLET SYSTEM

Maximum Intake Air Restriction (Includes piping)

With Clean Filter Element - mm H ₂ O (in. H ₂ O)	400	(15.7)
With Dirty Filter Element - mm H ₂ O (in. H ₂ O)	635	(25.0)

EXHAUST SYSTEM

Maximum Allowable Back Pressure - mm H ₂ O (in. H ₂ O)	600	(23.6)
--	-----	--------

LUBRICATION SYSTEM

Oil Pressure at Idle - kgf/cm ² (psi)	2~3	(29~43)
at Rate Speed - kgf/cm ² (psi)	5~6	(71~86)
Maximum Oil Temperature - °C(°F)	110	(230)
Oil Capacity of Standard Pan High - liter (U.S. gal)	70	(18.5)
Low - liter (U.S. gal)	50	(13.2)
Total System Capacity (Includes Oil Filter) - liter (U.S. gal)	80	(21.1)
Maximum Angle of Installation (Std. Pan) Front Down	10°	
(Engine Only) Front Up	12°	
Side to Side	22.5°	

COOLING SYSTEM

Coolant Capacity (Engine only) - liter (U.S. gal)	45	(11.9)
Maximum External Friction Head at Engine Outlet - kgf/cm ² (psi)	0.35	(5.0)
Maximum Static Head of Coolant above Crankshaft Center - m(ft)	10	(32.8)
Maximum Outlet Pressure of Engine Water Pump - kgf/cm ² (psi)	1.7	(24.3)
Standard Thermostat (modulating) Range- °C(°F)	65~85	(149~185)
Maximum Coolant Temperature at Engine Outlet- °C(°F)	98	(208)
Minimum Coolant Expansion Space - % of System Capacity	10	
Maximum Coolant Temperature at Intercooler Inlet, TK type- °C(°F)		
Maximum Air Restriction on Discharge Side of Radiator and Fan-mm H ₂ O(in. H ₂ O)	10	(0.4)

The specifications are subject to change without notice.

APPLICATION : GENERATOR

Pub. No. T0212-0001E Rev.2 2/4

FUEL SYSTEM

Fuel Injector	Bosch P Type × 1
Maximum Suction Head of Feed Pump - mm Hg (in. Hg)	75 (3.0)
Maximum Static Head of Return & Leak Pipe - mm Hg (in.Hg)	150 (5.9)

STARTING SYSTEM

Battery Charging Alternator - V-Ah	24-30
Starting Motor Capacity - V -kW	24-6.0
Maximum Allowable Resistance of Cranking Circuit - m Ω	2.5
Recommended Minimum Battery Capacity	
At 5°C(41°F) and above - Ah	200
Below 5°C(41°F) through - 5°C(23°F)	400

The specifications are subject to change without notice.

APPLICATION : GENERATOR

Pub. No. T0212-0001E Rev.2 3/4

S6A3-PTA

SPECIFICATION SHEET

ENGINE RATING

All data represent net performance with standard accessories such as air cleaner, inlet /exhaust manifolds, fuel oil system, L.O. pump, etc. under the condition of 100kPa(29.6inHg) barometric pressure, 77°F(25°C) ambient temperature and 30% relative humidity.

ITEM	UNIT	STAND-BY POWER			PRIME POWER			CONTINUOUS C		CONTINUOUS D	
		60Hz	50Hz	60Hz	60Hz	50Hz	60Hz	60Hz	50Hz	60Hz	50Hz
Engine Speed	rpm	1800	1500	1200	1800	1500	1200	1800	1500	1800	1500
No. of Cylinders		6									
Bore	mm (in.)	150 (5.91)									
Stroke	mm (in.)	175 (6.89)									
Displacement	liter (in. ³)	18.56 (1133)									
Brake Horse power without Fan	HP (kW)	684 (510)	590 (440)	469 (350)	617 (460)	536 (400)	422 (315)	529 (395)	456 (340)	469 (350)	409 (305)
Brake Mean Effective Pressure without Fan	kgf/cm ² (psi)	18.7 (266)	19.3 (274)	19.2 (273)	16.9 (240)	17.6 (250)	17.3 (246)	14.5 (206)	14.9 (212)	12.8 (182)	13.4 (191)
Mean Piston Speed	m/s (ft/min)	10.5 (2067)	8.8 (1732)	7.0 (1378)	10.5 (2067)	8.8 (1732)	7.0 (1378)	10.5 (2067)	8.8 (1732)	10.5 (2067)	8.8 (1732)
Maximum Regenerative Power Absorption Capacity without Fan	HP (kW)	73 (54)	53 (40)	34 (25)	73 (54)	53 (40)	34 (25)	73 (54)	53 (40)	73 (54)	53 (40)
Intake Air flow	m ³ /min (CFM)	44 (1554)	38 (1342)	29 (1024)	40 (1412)	34 (1201)	26 (918)	34 (1201)	28 (989)	30 (1059)	26 (918)
Exhaust Gas Flow	m ³ /min (CFM)	118 (4167)	101 (3566)	78 (2754)	105 (3708)	89 (3143)	69 (2436)	90 (3178)	75 (2648)	80 (2825)	68 (2401)
Coolant Flow	liter/min (U.S. GPM)	650 (172)	580 (153)	433 (114)	650 (172)	580 (153)	433 (114)	650 (172)	580 (153)	650 (172)	580 (153)
Coolant Flow to Intercooler (TK only)	liter/min (U.S. GPM)	—	—	—	—	—	—	—	—	—	—
Cooling Air Flow (Std. Fan)	m ³ /min (CFM)	720 (25423)	540 (19067)	438 (15466)	720 (25423)	540 (19067)	438 (15466)	720 (25423)	540 (19067)	720 (25423)	540 (19067)
Fan Loss Horse Power (Std. Fan)	HP (kW)	27 (20)	14 (10)	14 (10)	27 (20)	14 (10)	14 (10)	27 (20)	14 (10)	27 (20)	14 (10)
Radiated Heat to Ambient	kcal/hr (BTU/min)	33489 (2215)	28706 (1899)	22101 (1462)	29831 (1973)	25422 (1681)	19757 (1307)	25576 (1692)	21349 (1412)	22819 (1509)	19274 (1275)
Heat Rejection to Coolant	kcal/hr (BTU/min)	279072 (18457)	239216 (15821)	184176 (12181)	248589 (16441)	211854 (14012)	164643 (10889)	213134 (14096)	177908 (11767)	190156 (12577)	160614 (10623)
Heat Rejection to Inter Cooler (TK Version)	kcal/hr (BTU/min)	—	—	—	—	—	—	—	—	—	—
Heat Rejection to Exhaust	kcal/hr (BTU/min)	364987 (24140)	310495 (20536)	229595 (15185)	320173 (21176)	266331 (17615)	203488 (13458)	274508 (18156)	219882 (14543)	246817 (16324)	200223 (13242)
Noise Level (1 m height & distance) (excludes, Intake, Exhaust & Fan)	dB(A)	TBD	TBD	TBD	TBD	TBD	TBD	TBD	TBD	TBD	TBD

The specifications are subject to change without notice.

APPLICATION : GENERATOR

Pub. No. T0212-0001E Rev.2 4/4



**MITSUBISHI DIESEL ENGINE
TECHNICAL INFORMATION**

ITEM NO.

T0307-0003E (1/2)

DATE

July, 2006

Elastic data of S6A3 Engine

Elastic data of S6A3 Engine are enclosed herein.

Revision	First Edition : July, 2006 (Refer to ELASTIC-S6A3-PTA Oct.,2003, S6A3.0)	Engine Engineering Department Large Engine Design Section		
		Approved by	Checked by	Drawn by
		S.MATSUSHITA	T.HASHIGUCHI	T.H.

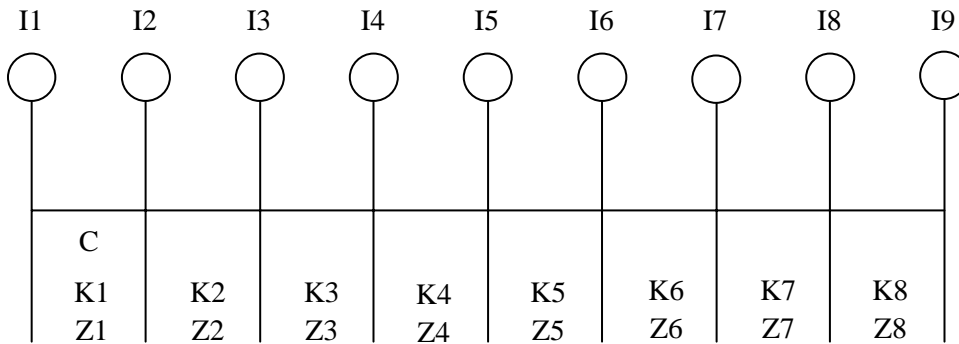

S6A3-PTA ELASTIC DATA

	Moment of inertia J kg.m ²	Damping coefficient Nm/rad/s	Spring const. x10 ⁷ Nm/rad	Tensile strength N/mm ²	Section modulus cm ³
I1	DAMPER	0.412	C=392.3	K1=0	Z1 =0.0
I2	PULLEY	0.331	—	K2=0.907	Z2 =209.5
I3	No.1 CRANK	0.331	—	K3=0.505	Z3 =209.5
I4	No.2 CRANK	0.217	—	K4=0.505	Z4 =209.5
I5	No.3 CRANK	0.331	—	K5=0.505	Z5 =209.5
I6	No.4 CRANK	0.331	—	K6=0.505	Z6 =209.5
I7	No.5 CRANK	0.217	—	K7=0.505	Z7 =209.5
I8	No.6 CRANK	0.331	—	K8=0.876	Z8 =209.5
I9	FLYWHEEL 18in 14in	5.93 1.99	—		

Hysteresis constant:170 No. of Cylinder: 6 Bore:150mm Stroke:175mm

Length of Con-Rod: 290mm Weight of Reciprocating Parts: 8.649 kg

Firing order:1-5-3-6-2-4

Firing interval:0-120-240-360-480-600

APPLICATION : LAND USE

The data is subject to change without notice.



MITSUBISHI HEAVY INDUSTRIES, LTD.
GENERAL MACHINERY & SPECIAL VEHICLE



**MITSUBISHI DIESEL ENGINE
TECHNICAL INFORMATION**

ITEM NO.

T0402-0001E Rev.1 (1/2)

DATE

May, 2008

Exhaust Gas Emission Data

Exhaust Gas Emission Data is enclosed herein.

These data are subject to change without notice.

Revision	First Edition : May, 2008	Engine Engineering Department Engine System Designing Section		
	Rev.1: February, 2013			
		Approved by	Checked by	Drawn by
		T.HASHIGUCHI	T.OGURA	K.N.

EXHAUST GAS EMISSION DATA OF DIESEL ENGINE FOR GENERATOR
For Reference

MODEL	S6A3-P TA		S12A2-P TA		S12H-P TA		S6R-P TA		S12R-P TA		S12R-PTA2		S12R-PTAA2 (W/FAN)		S16R-P TA		S16R-PTA2		S16R-PTAA2 (W/FAN)		S16R2-PTAW
	400/ 1500	890	679/ 1500	825	935/ 1500	761/ 1800	930/ 1500	515/ 1500	1110/ 1500	1190/ 1800	1195/ 1500	1340/ 1800	1277/ 1500	1480/ 1500	1590/ 1800	1630/ 1500	1775/ 1800	1684/ 1500	1895/ 1800	1800	
Prime Rating kW/min ⁻¹ (without fan)																					
NOx	900	890	852	825	935	877	901	940	852	940	950	852	940	925	852	950	852	828	754	659	
g/Nm ³	3.7	3.7	3.5	3.4	3.8	3.6	3.7	3.5	3.7	3.5	3.9	3.7	3.5	3.8	3.7	3.9	3.4	3.1	3.6		
g/AW·h	8.6	8.6	7.7	7.7	8.8	8.2	8.4	8.4	7.7	8.4	8.8	7.7	8.4	8.7	7.7	8.8	7.7	7.1	5.8		
CO	(220)	(210)	(220)	(210)	(310)	(210)	310	210	(310)	(210)	(310)	(210)	(320)	(310)	(210)	(310)	(320)	(200)	119		
g/Nm ³	(0.44)	(0.45)	(0.44)	(0.45)	(0.59)	(0.43)	0.52	0.39	(0.59)	(0.43)	(0.59)	(0.43)	(0.55)	(0.56)	(0.43)	(0.59)	(0.55)	(0.42)	0.4		
g/AW·h	(1.2)	1.4	(1.2)	1.4	(1.8)	(1.4)	1.5	1.2	(1.8)	(1.4)	(1.8)	(1.2)	(1.5)	(1.6)	(1.4)	(1.8)	(1.5)	(1.2)	0.5		
HC	(50)	(50)	(50)	(50)	(110)	(120)	110	120	(110)	(120)	(110)	(120)	(110)	(110)	(120)	(110)	(110)	(120)	35		
g/Nm ³	(0.05)	(0.06)	(0.05)	(0.06)	(0.11)	(0.13)	0.09	0.11	(0.11)	(0.13)	(0.11)	(0.13)	(0.10)	(0.10)	(0.13)	(0.11)	(0.10)	(0.13)	0.19		
g/AW·h	(0.15)	(0.18)	(0.15)	(0.18)	(0.31)	(0.38)	0.27	0.34	(0.31)	(0.38)	(0.31)	(0.35)	(0.29)	(0.29)	(0.38)	(0.31)	(0.29)	(0.38)	0.10		
CO ₂	6.7	6.2	6.7	6.2	6.9	6.5	8.0	7.1	6.9	6.5	6.7	6.5	6.7	6.7	6.5	6.7	6.5	6.5	8.0		
g/AW·h	619	646	619	646	619	625	598	619	619	625	620	613	619	619	612	620	613	619	612	0.4	
PM	0.12	0.12	0.12	0.11	0.12	0.11	0.10	0.12	0.12	0.11	0.10	0.09	0.09	0.11	0.12	0.11	0.12	0.09	0.07	0.03	
g/AW·h	0.37	0.37	0.38	0.37	0.38	0.37	0.34	0.35	0.35	0.37	0.34	0.33	0.33	0.33	0.39	0.33	0.33	0.31	0.31	0.04	

Notes

- Allowance: +25%
- Condition: 100kPa(750mmHg) barometric pressure, 298K(25°C) ambient temperature and 30% relative humidity.
- NOx, CO, HC[PPM]: with 13% O₂ Level.
- NOx, CO, HC, Particulates[$\mu\text{g}/\text{Nm}^3$]: with 5% O₂ Level.
- NOx, CO, HC, Particulates[$\mu\text{g}/\text{PS}\cdot\text{h}$]: with 13% O₂ Level.
- CO₂[%]: Calculated Data.
- (): Estimated Data.
- *1: Standby Rating
- These data are subject to change without notice.





**MITSUBISHI DIESEL ENGINE
TECHNICAL INFORMATION**

ITEM NO.

T33-0100-E

DATE

Jun. 1999

FUEL CONSUMPTION

(SB, SA, SH, SR SERIES ENGINES FOR GENERATOR DRIVE)

ENGINE MODEL	ENGINE rpm	REMARKS
S6B-PTA, PTK	1500	W/Fan, W/O Fan
	1800	
S6B3-PTA, PTK	1200	W/Fan, W/O Fan
	1500	
S6A3-PTA, PTK	1200	W/Fan, W/O Fan
	1500	
S12A2-PTA, PTK	1200	W/Fan, W/O Fan
	1500	
S12H-PTA	1500	W/Fan, W/O Fan
	1800	
S6R-PTA, PTK	1200	W/Fan, W/O Fan
	1500	
S6R2-PTA, PTK	1000	W/Fan, W/O Fan
	1200	
S12R-PTA, PTK	1200	W/Fan, W/O Fan
	1500	
S12R-PTA2, PTK2	1500	W/Fan, W/O Fan
	1800	
S16R-PTA, PTK	1200	W/Fan, W/O Fan
	1500	
S16R-PTA2, PTK2	1500	W/Fan, W/O Fan
	1800	
S6A3-PTAA	1500	W/Fan
	1800	
S6R2-PTAA	1500	W/Fan
S12R-PTAA2	1500	W/Fan
	1800	
S16R-PTAA2	1500	W/Fan
	1800	

First Edition : Jun. 1999

Engine Engineering Department
Large Engine Design Section

Revision

Approved by

Checked by

Drawn by

SPECIFIC FUEL CONSUMPTION MODEL : S6B 1500rpm

- 1. STANDARD : ISO or JIS
- 2. ALLOWANCE : +5%

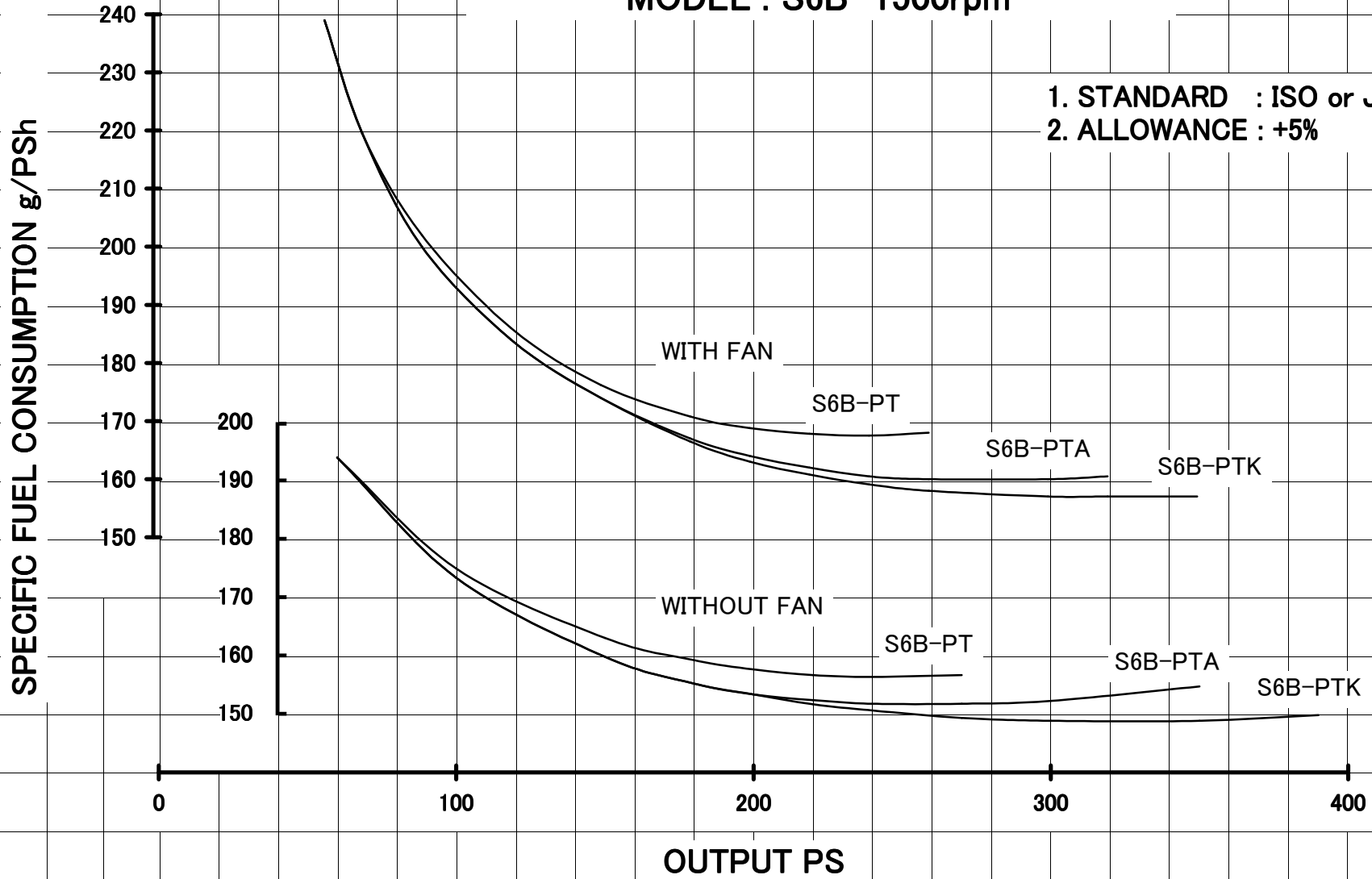

SPECIFIC FUEL CONSUMPTION MODEL : S6B 1800rpm

- 1. STANDARD : ISO or JIS
- 2. ALLOWANCE : +5%

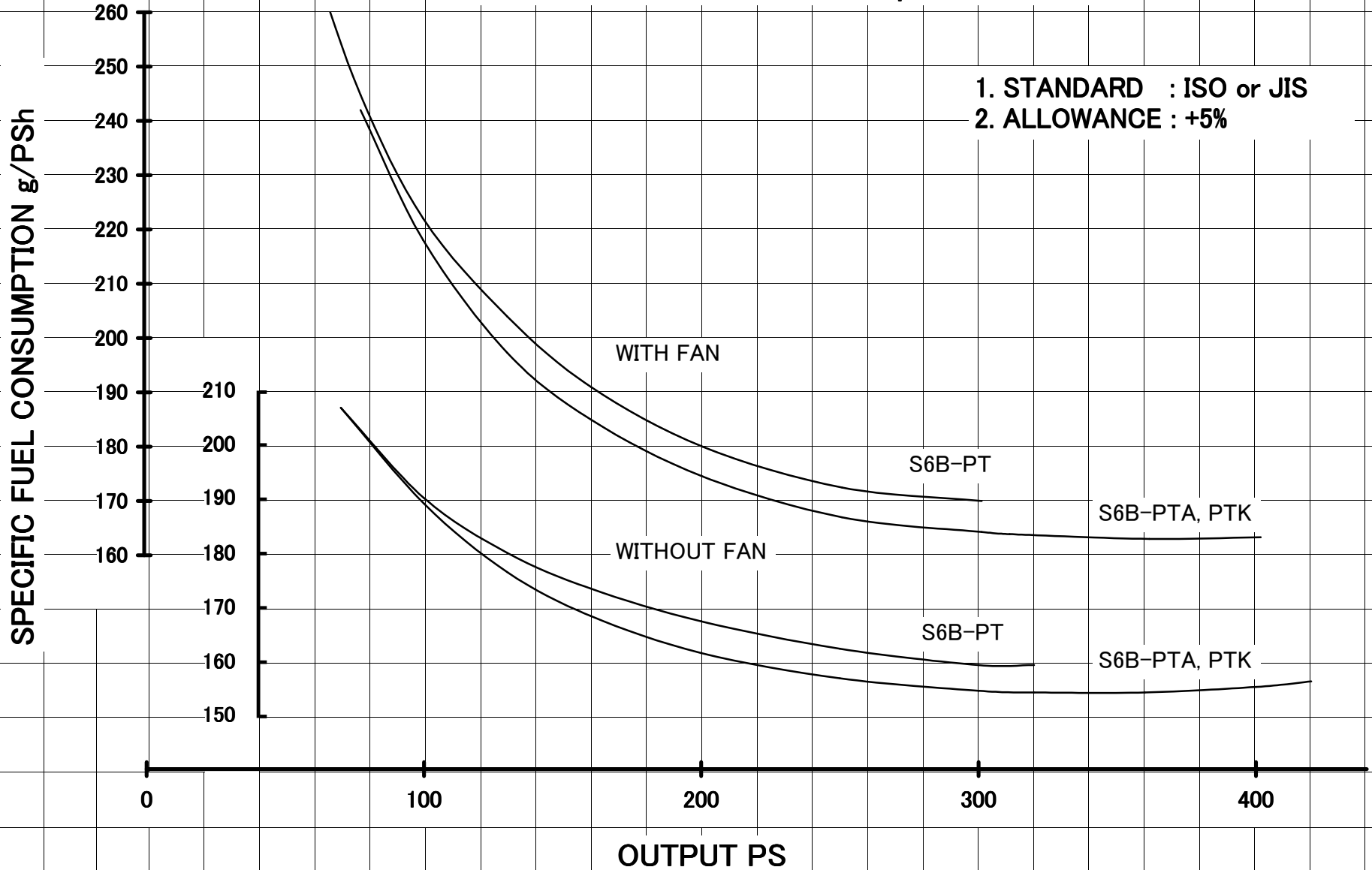

SPECIFIC FUEL CONSUMPTION MODEL : S6B3 1200rpm

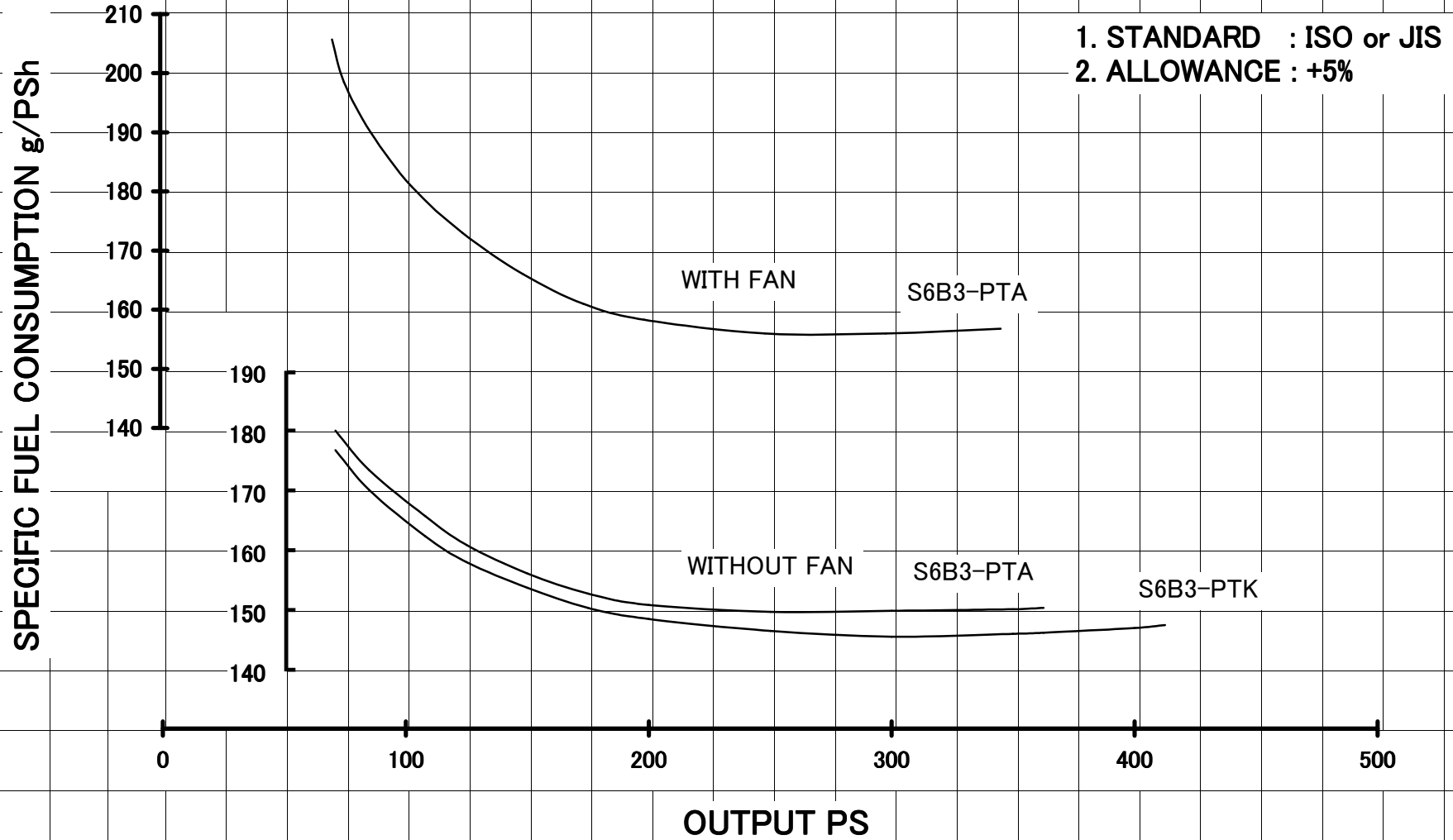

SPECIFIC FUEL CONSUMPTION

MODEL : S6B3 1500rpm

1. STANDARD : ISO or JIS

2. ALLOWANCE : +5%

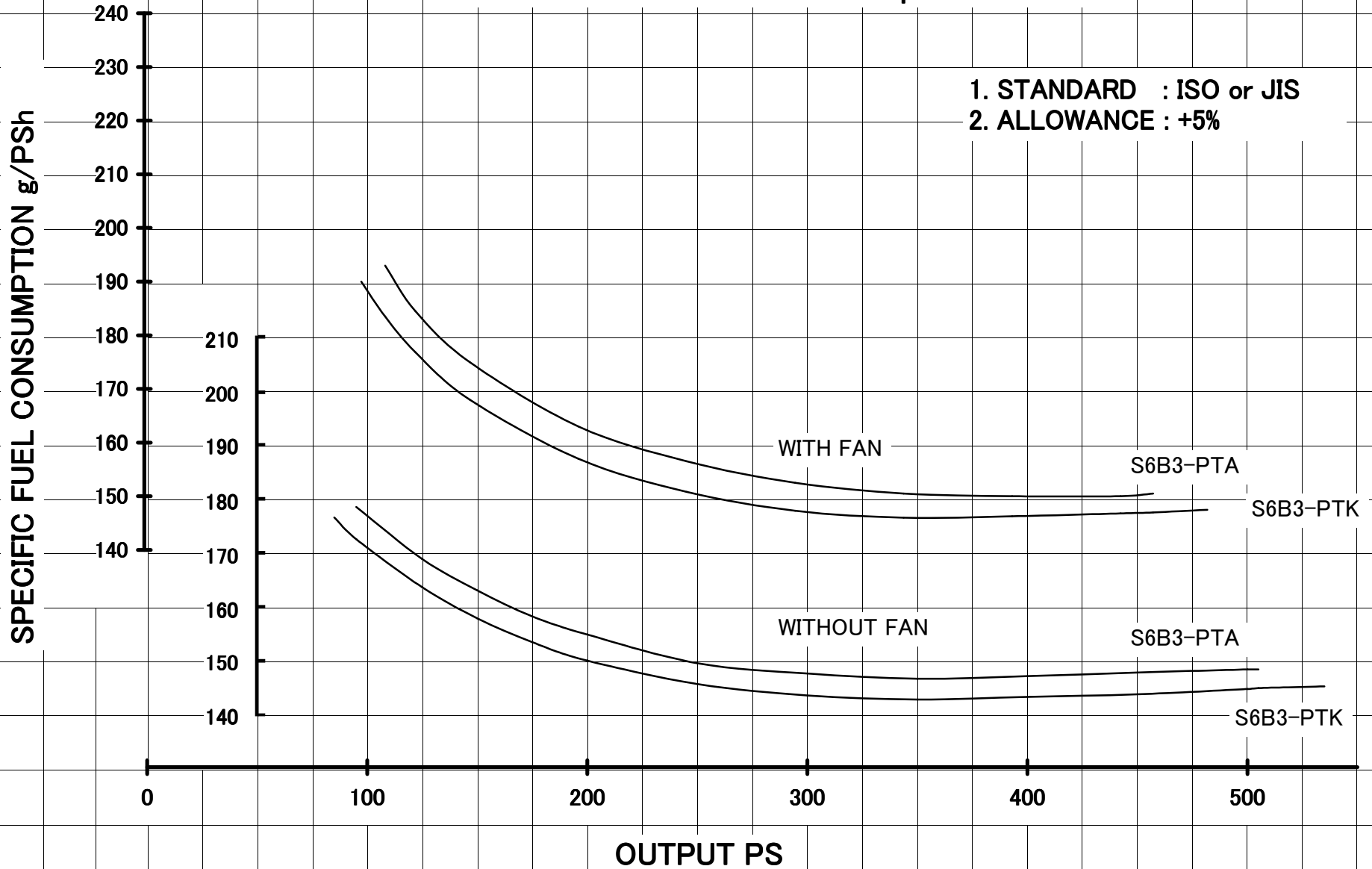

SPECIFIC FUEL CONSUMPTION MODEL : S6B3 1800rpm

- 1. STANDARD : ISO or JIS
- 2. ALLOWANCE : +5%

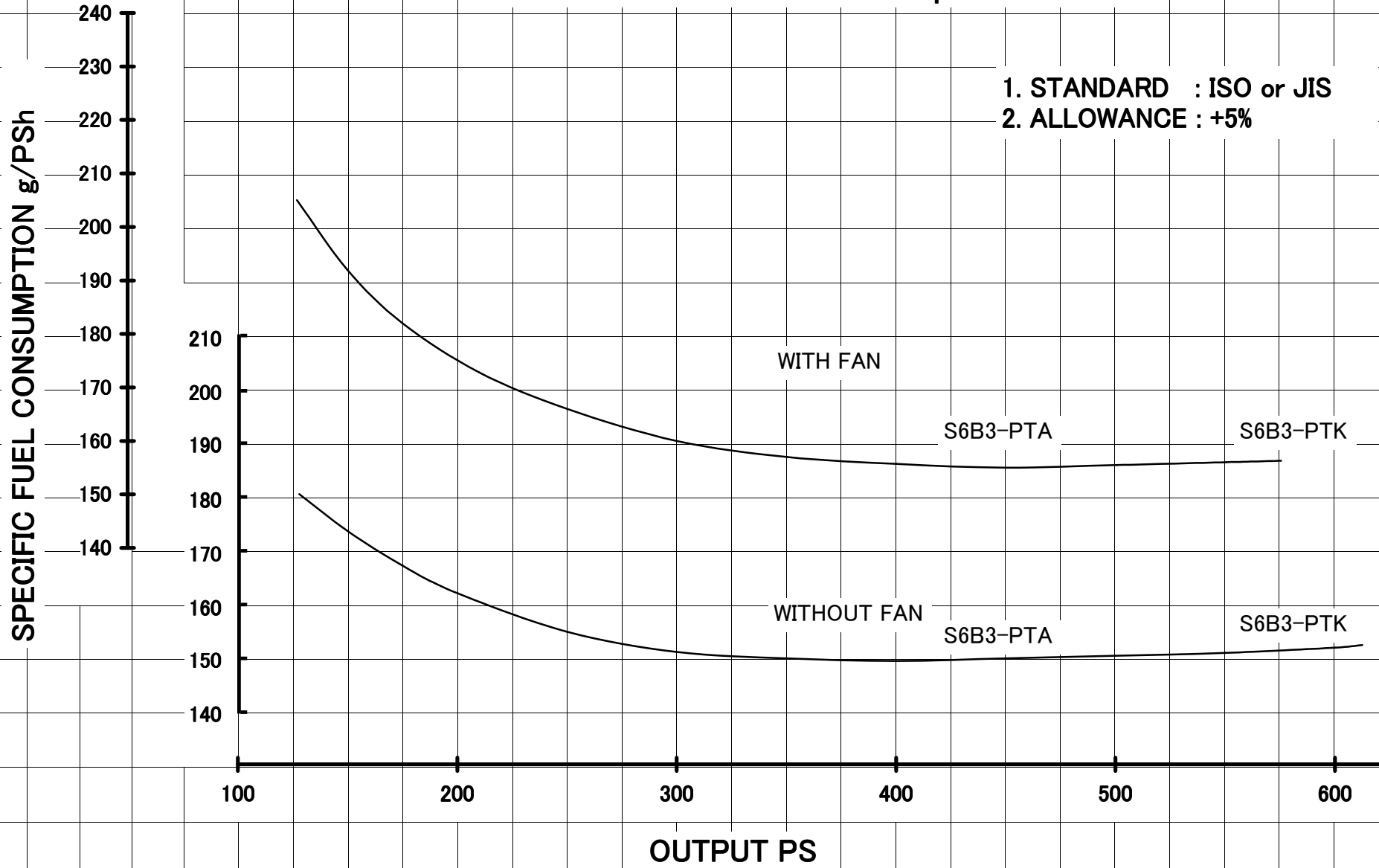

SPECIFIC FUEL CONSUMPTION

MODEL : S6A3 1200rpm

- 1. STANDARD : ISO or JIS
- 2. ALLOWANCE : +5%

SPECIFIC FUEL CONSUMPTION g/PS_h

210
200
190
180
170
160
150
140

190
180
170
160
150
140

WITH FAN

WITHOUT FAN

S6BA3-PTA

S6A3-PTK

0

100

200

300

400

500

OUTPUT PS

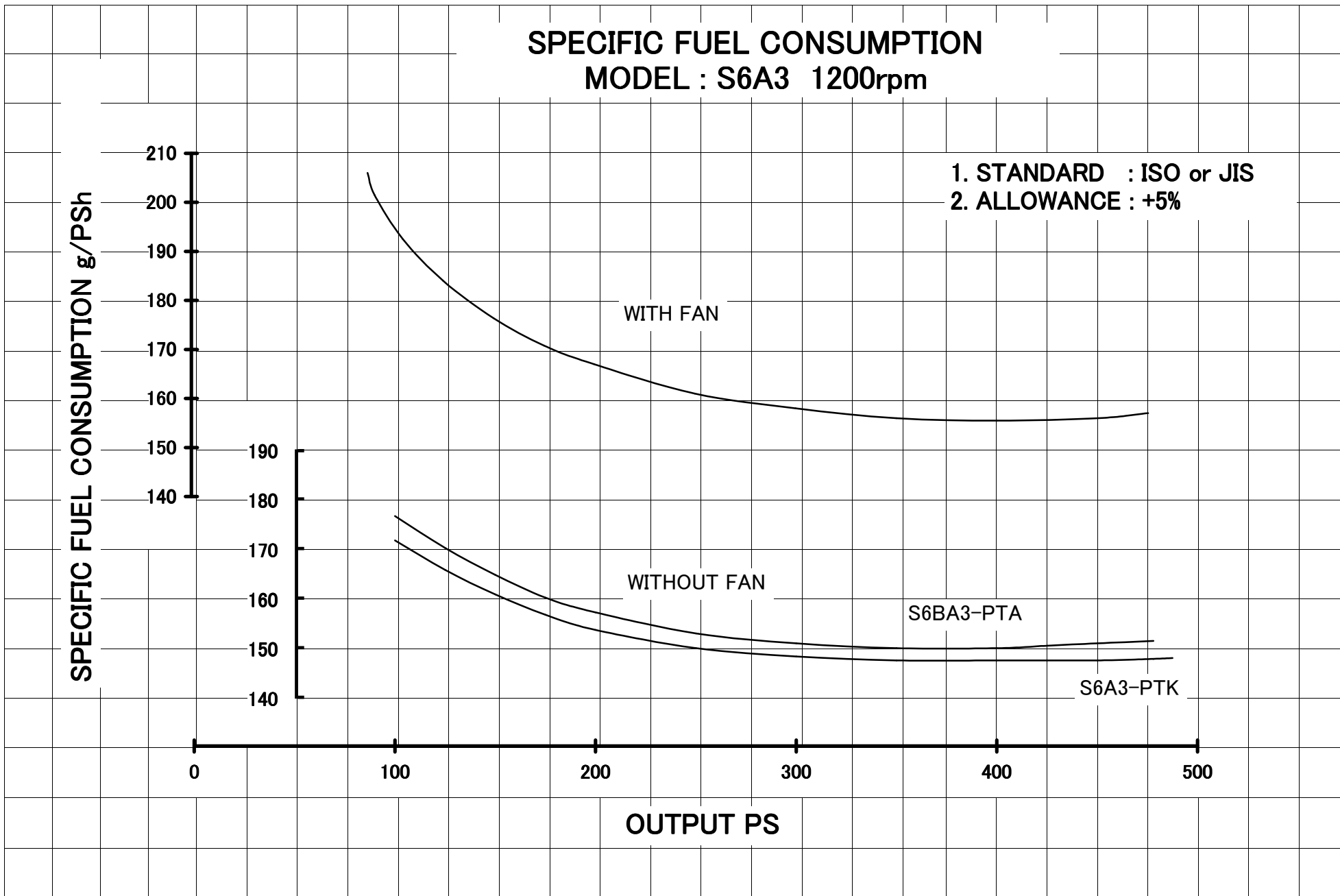

SPECIFIC FUEL CONSUMPTION

MODEL : S6A3 1500rpm

- 1. STANDARD : ISO or JIS
- 2. ALLOWANCE : +5%

SPECIFIC FUEL CONSUMPTION g/PSH

220
210
200
190
180
170
160
150
140

210
200
190
180
170
160
150
140

WITH FAN

S6A3-PTA

S6A3-PTK

WITHOUT FAN

S6A3-PTA

S6A3-PTK

0 100 200 300 400 500 600 700

OUTPUT PS

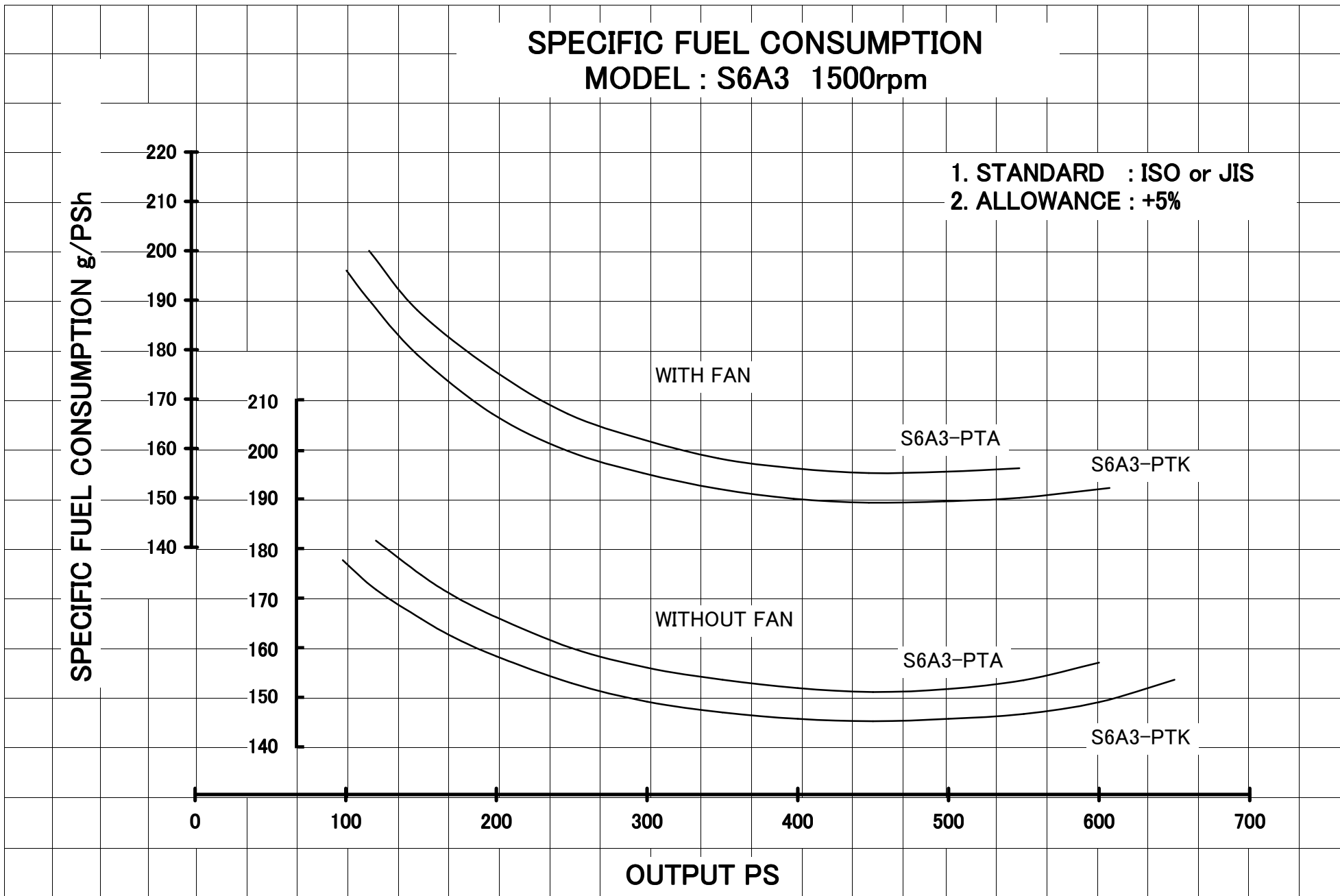

SPECIFIC FUEL CONSUMPTION

MODEL : S6A3 1800rpm

- 1. STANDARD : ISO or JIS
- 2. ALLOWANCE : +5%

SPECIFIC FUEL CONSUMPTION g/PS_h

230
220
210
200
190
180
170
160
150

210
200
190
180
170
160
150

WITH FAN

S6A3-PTA

S6A3-PTK

WITHOUT FAN

S6A3-PTA

S6A3-PTK

0

100

200

300

400

500

600

700

OUTPUT PS

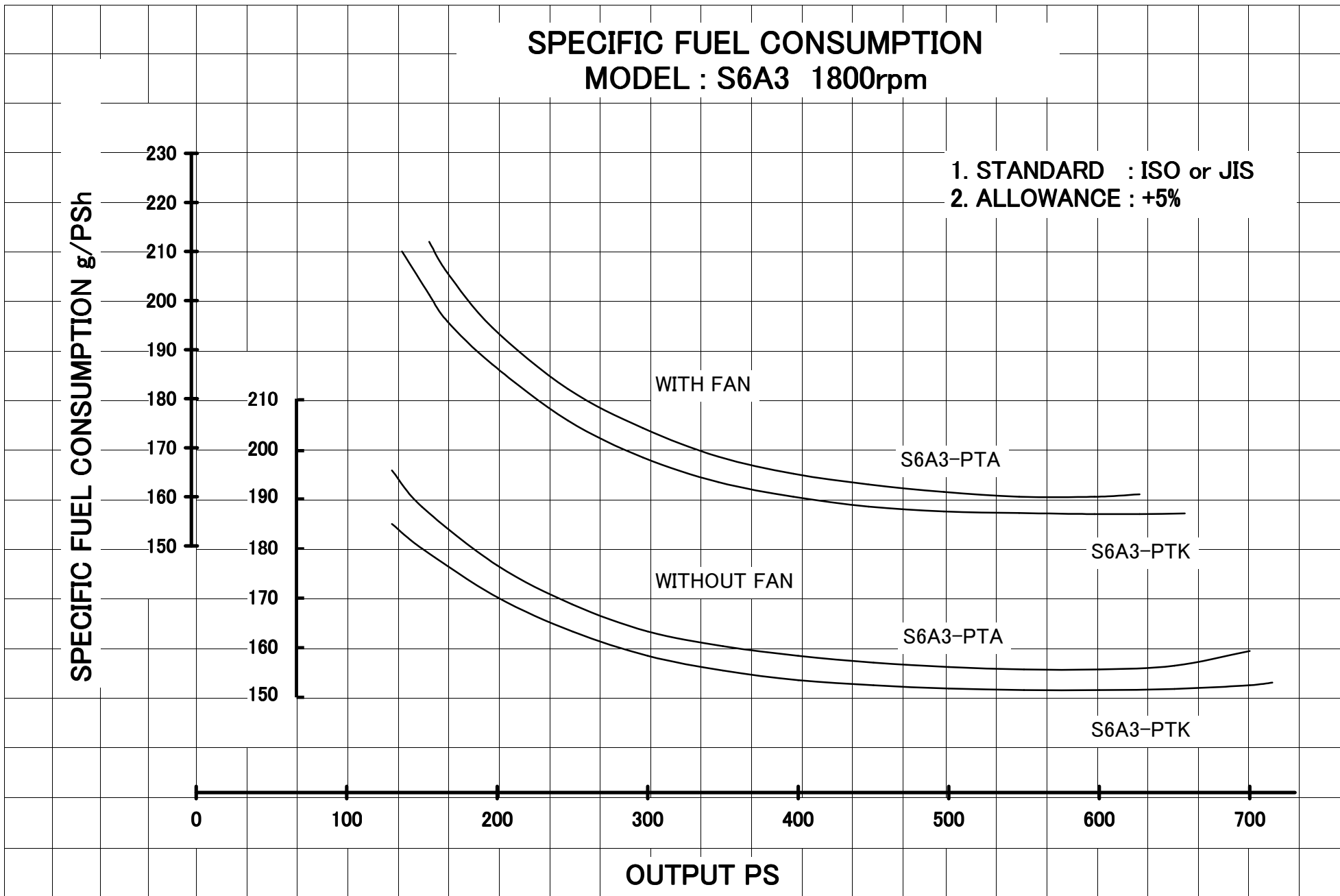

SPECIFIC FUEL CONSUMPTION MODEL : S12A2 1200rpm

- 1. STANDARD : ISO or JIS
- 2. ALLOWANCE : +5%

SPECIFIC FUEL CONSUMPTION g/PS_h

190
180
170
160
150

180
170
160
150

0

200

400

600

800

OUTPUT PS

WITH FAN

WITHOUT FAN

S12A2-PT

S12A2-PT

S12A2-PTA

S12A2-PTA

S12A2-PTK

S12A2-PTK

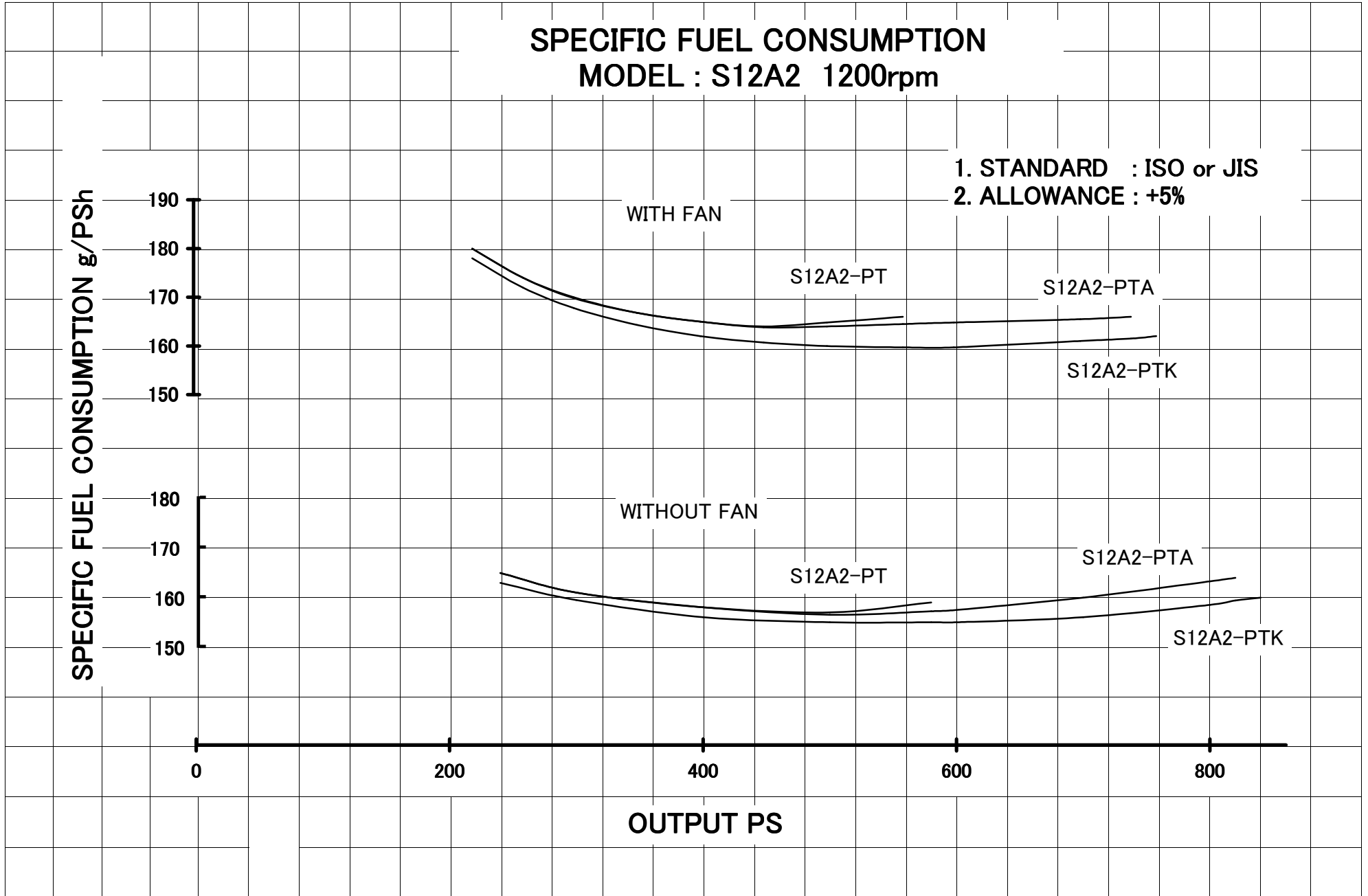

SPECIFIC FUEL CONSUMPTION MODEL : S12A2 1500rpm

- 1. STANDARD : ISO or JIS
- 2. ALLOWANCE : +5%

SPECIFIC FUEL CONSUMPTION g/PS_h

190
180
170
160
150

190
180
170
160
150
140

0

200

400

600

800

1000

OUTPUT PS

WITH FAN

S12A2-PT

S12A2-PTA

S12A2-PTK

WITHOUT FAN

S12A2-PT

S12A2-PTA

S12A2-PTK

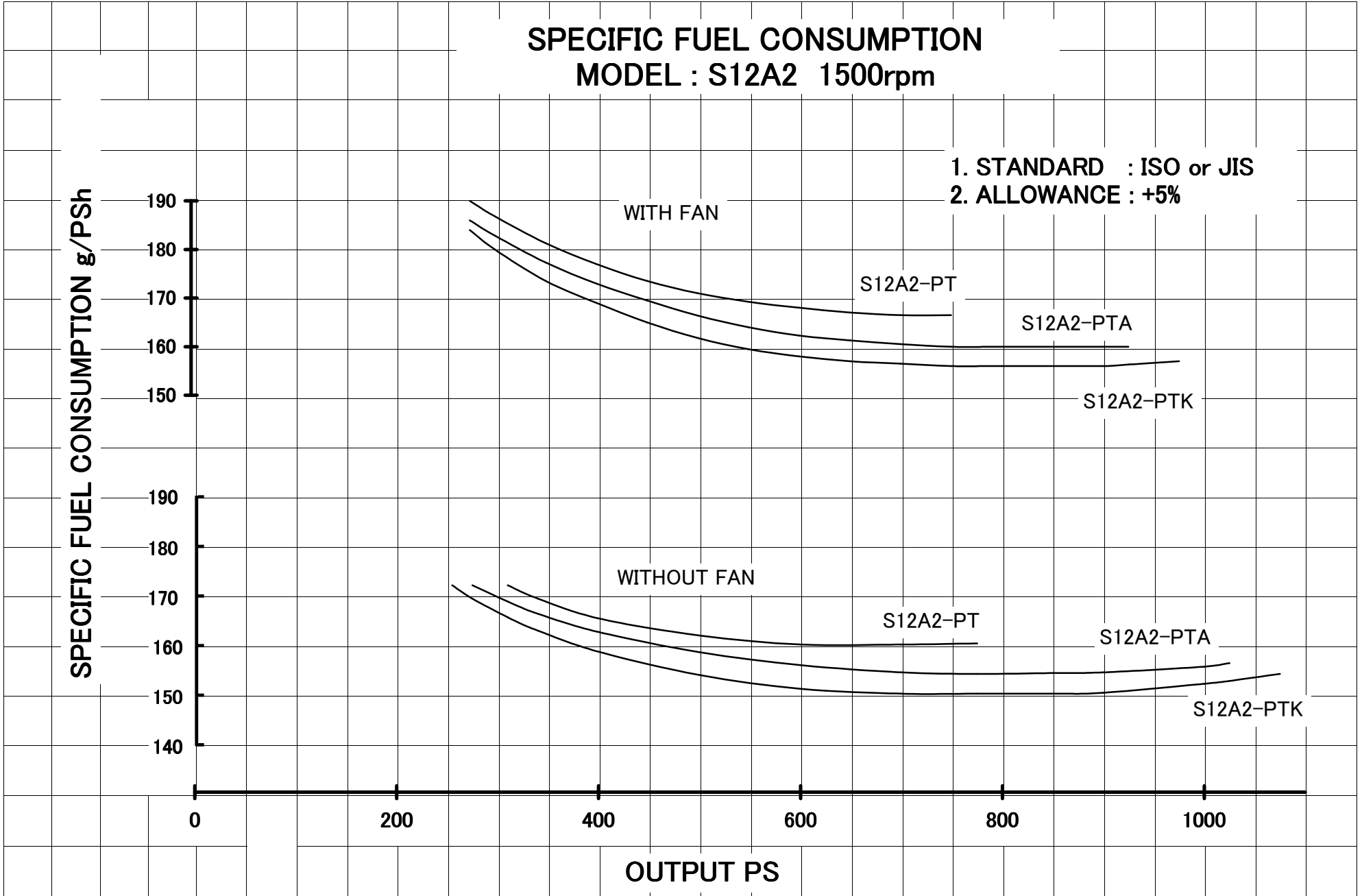

SPECIFIC FUEL CONSUMPTION MODEL : S12A2 1800rpm

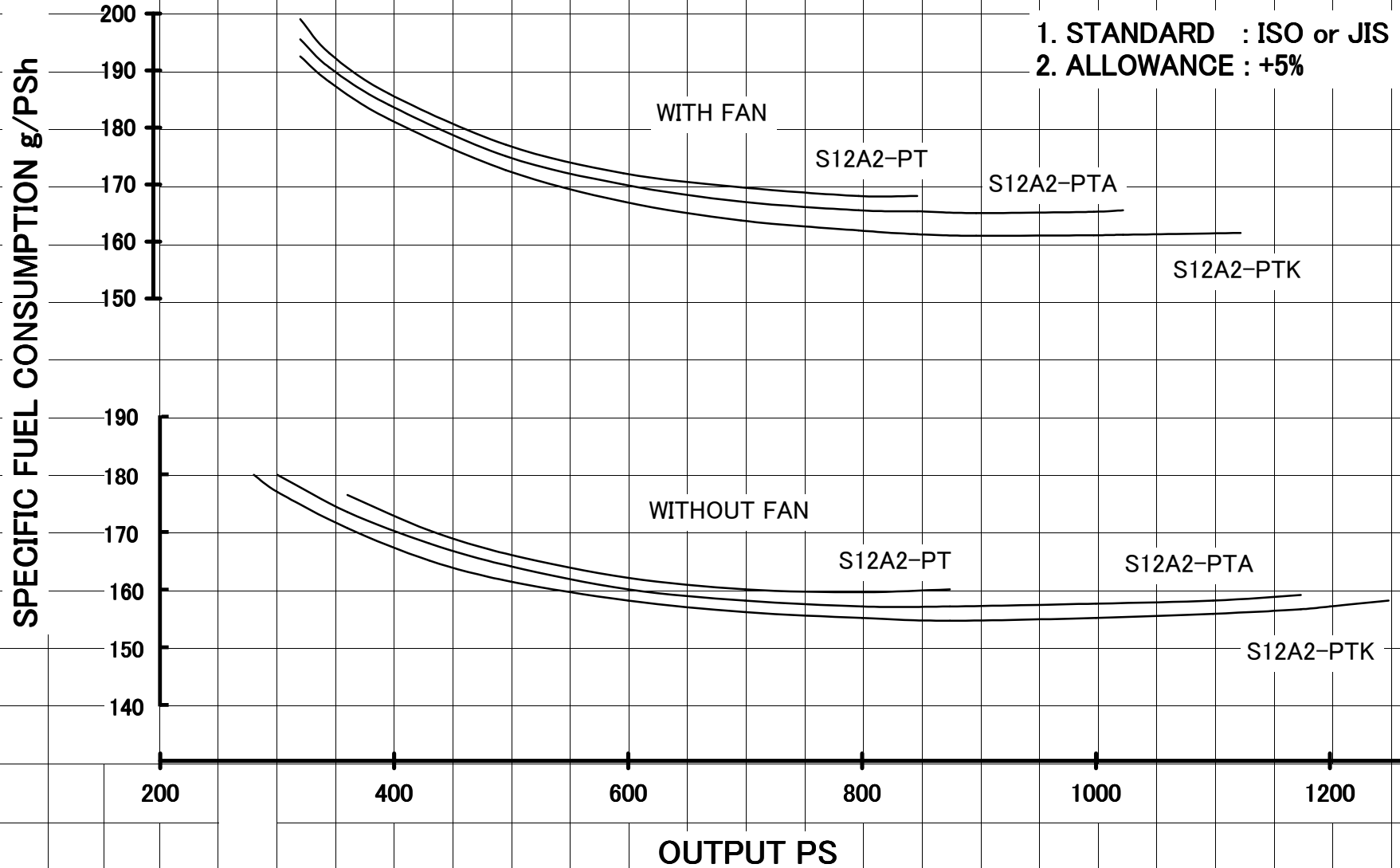

SPECIFIC FUEL CONSUMPTION MODEL : S6R 1200rpm

- 1. STANDARD : ISO or JIS
- 2. ALLOWANCE : +5%

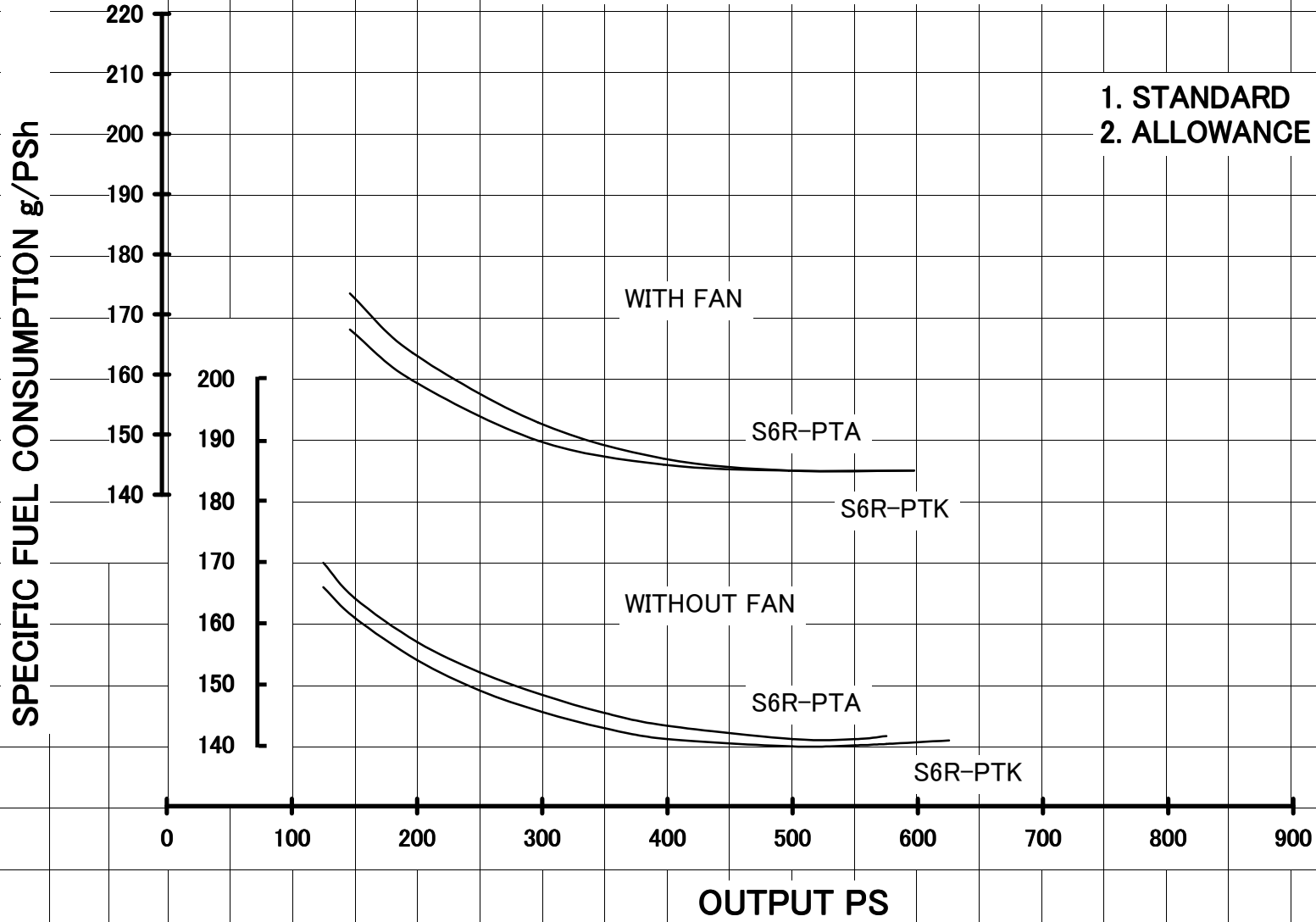

SPECIFIC FUEL CONSUMPTION

MODEL : S6R 1500rpm

1. STANDARD : ISO or JIS

2. ALLOWANCE : +5%

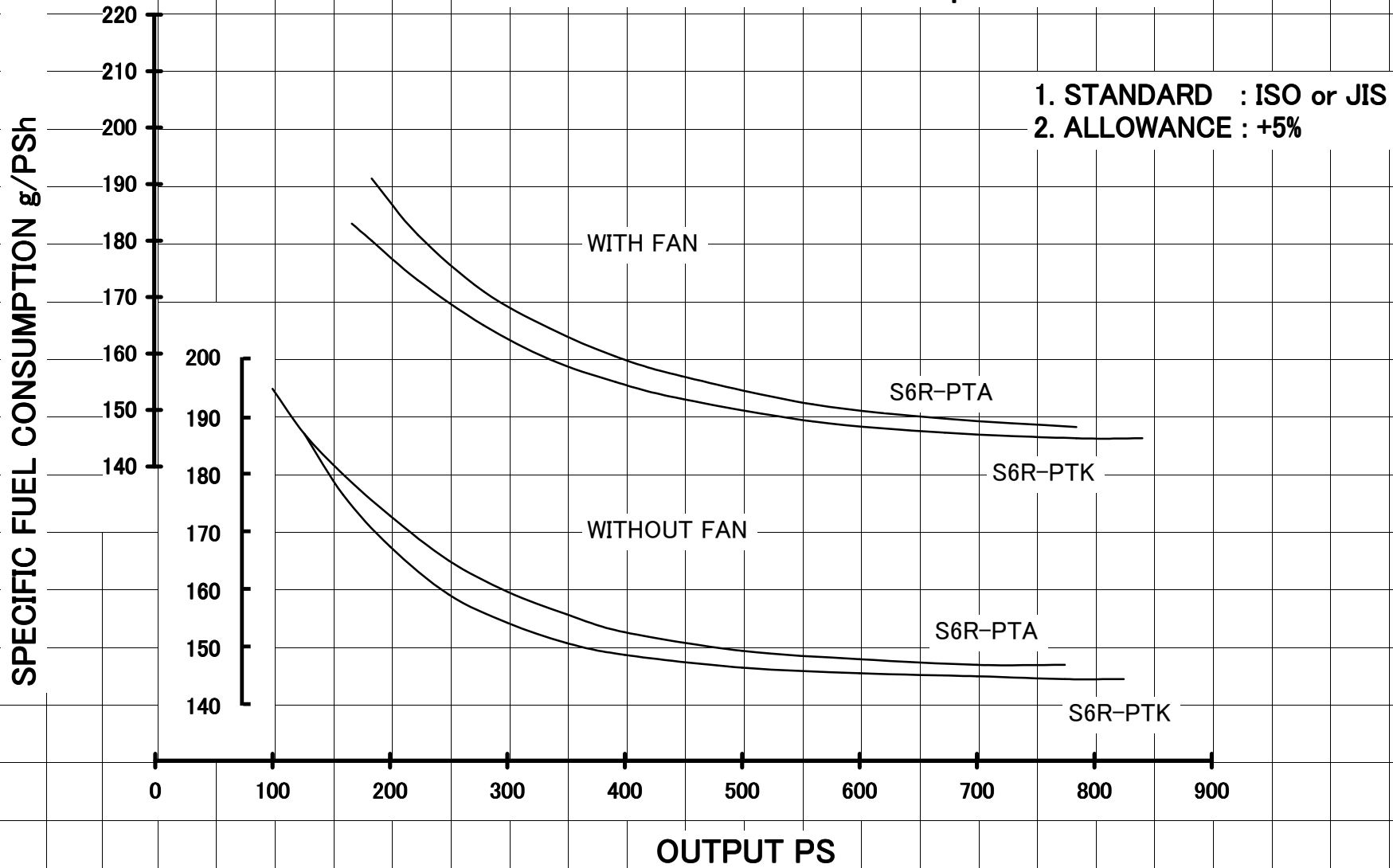

SPECIFIC FUEL CONSUMPTION MODEL : S6R 1800rpm

- 1. STANDARD : ISO or JIS
- 2. ALLOWANCE : +5%

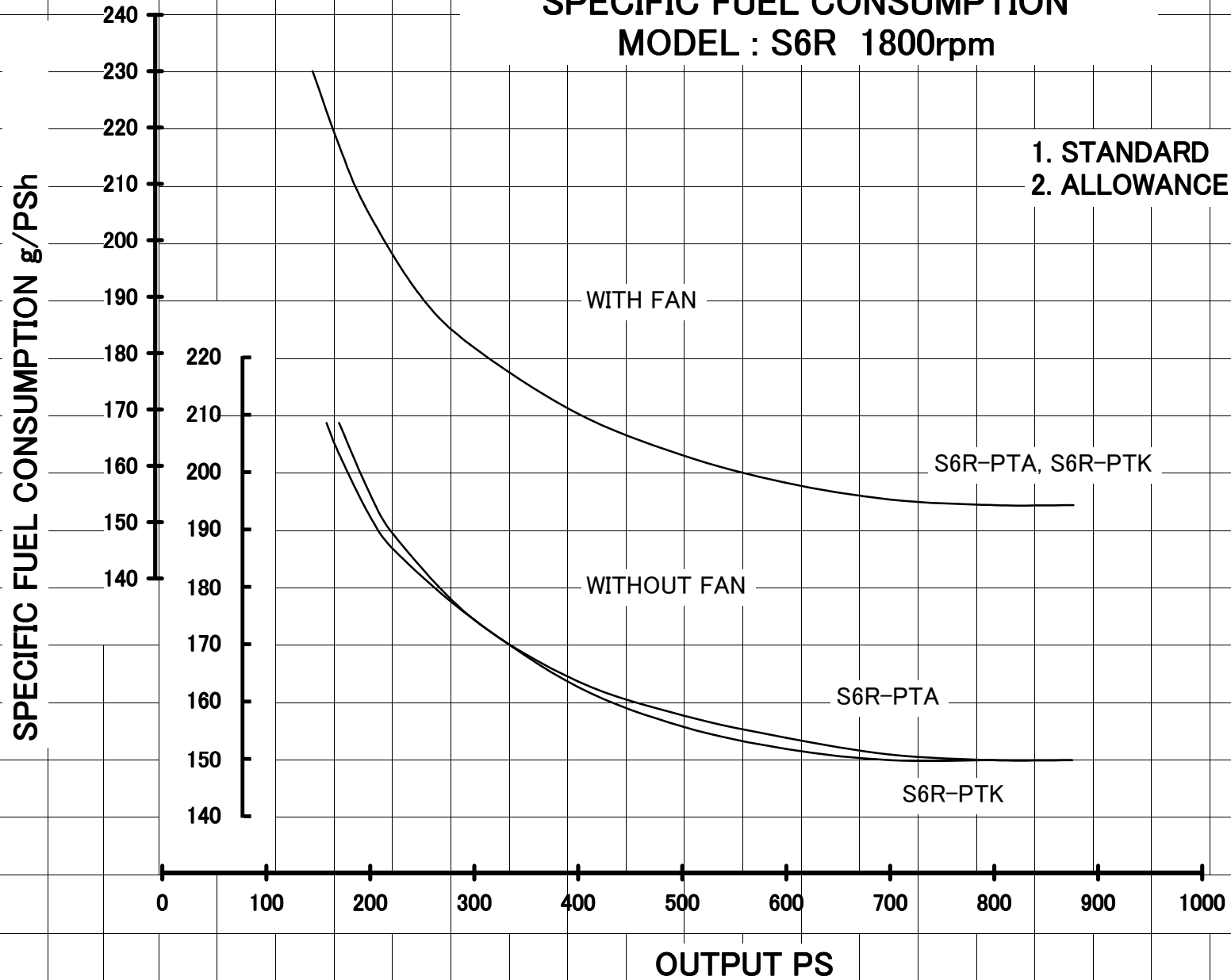

SPECIFIC FUEL CONSUMPTION MODEL : S6R2 1000rpm

- 1. STANDARD : ISO or JIS
- 2. ALLOWANCE : +5%

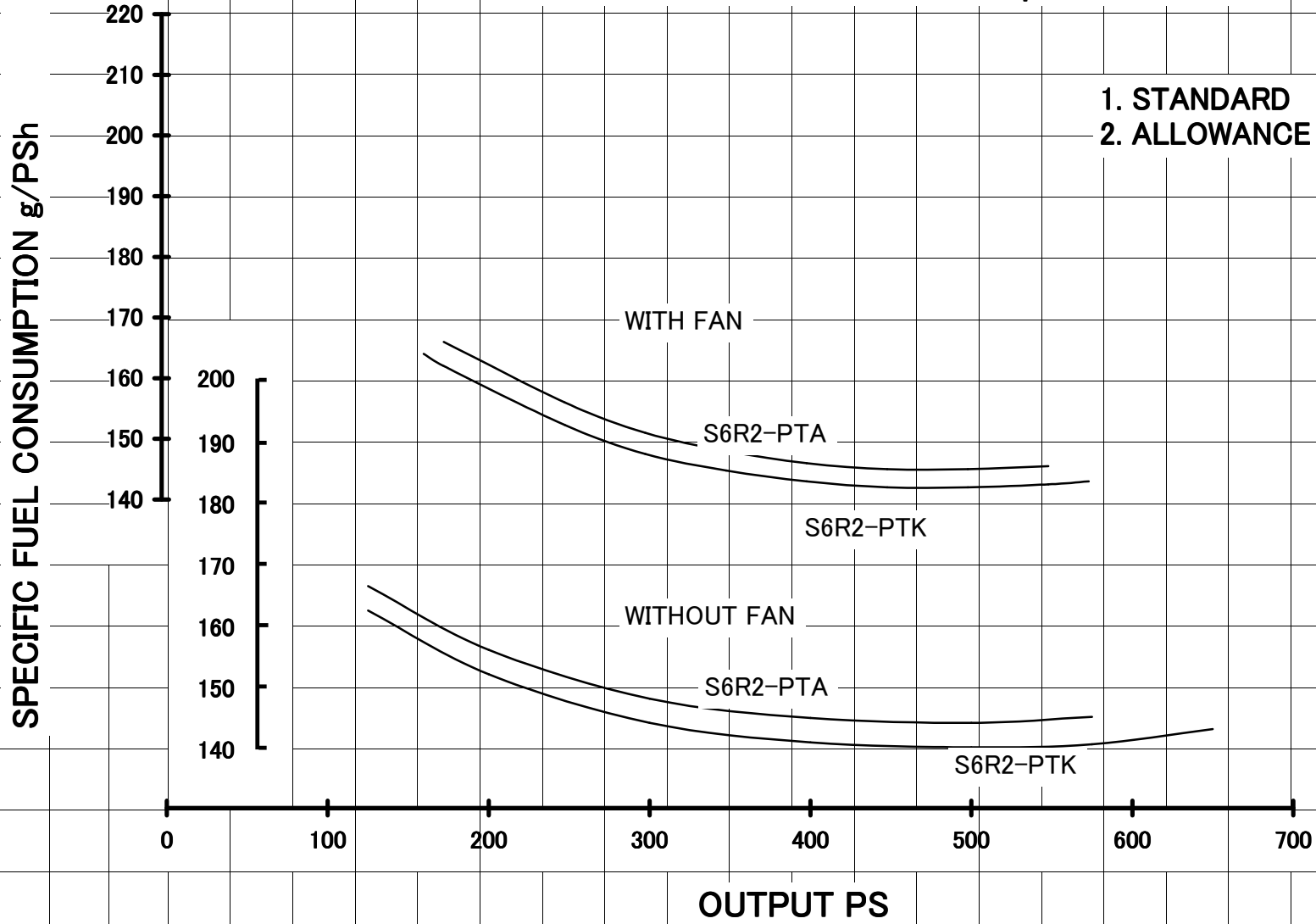

SPECIFIC FUEL CONSUMPTION

MODEL : S6R2 1200rpm

1. STANDARD : ISO or JIS

2. ALLOWANCE : +5%

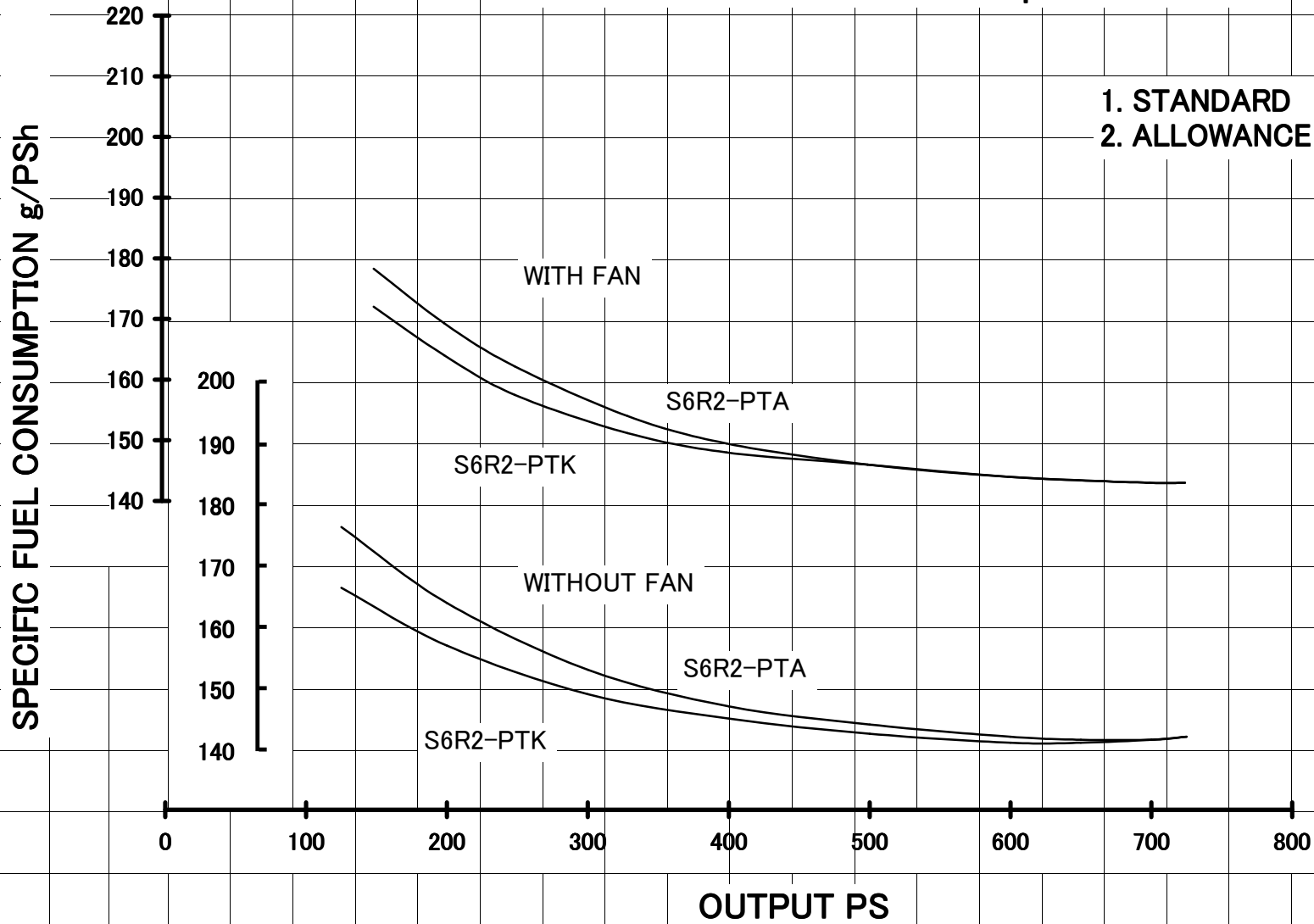

SPECIFIC FUEL CONSUMPTION MODEL : S6R2 1500rpm

- 1. STANDARD : ISO or JIS
- 2. ALLOWANCE : +5%

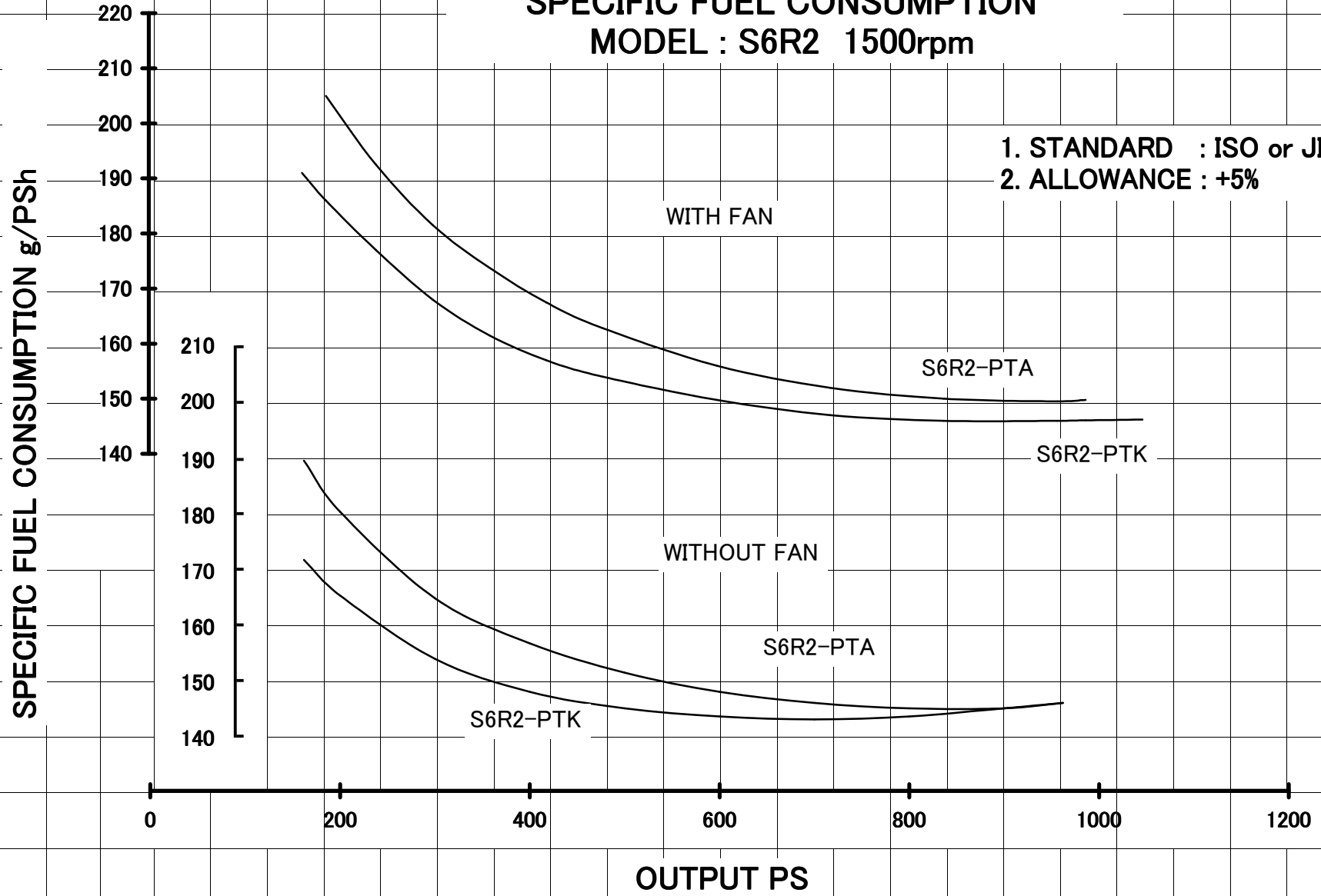

SPECIFIC FUEL CONSUMPTION MODEL : S12R 1200rpm

- 1. STANDARD : ISO or JIS
- 2. ALLOWANCE : +5%

SPECIFIC FUEL CONSUMPTION g/PS_h

200
190
180
170
160
150
140
190
180
170
160
150
140

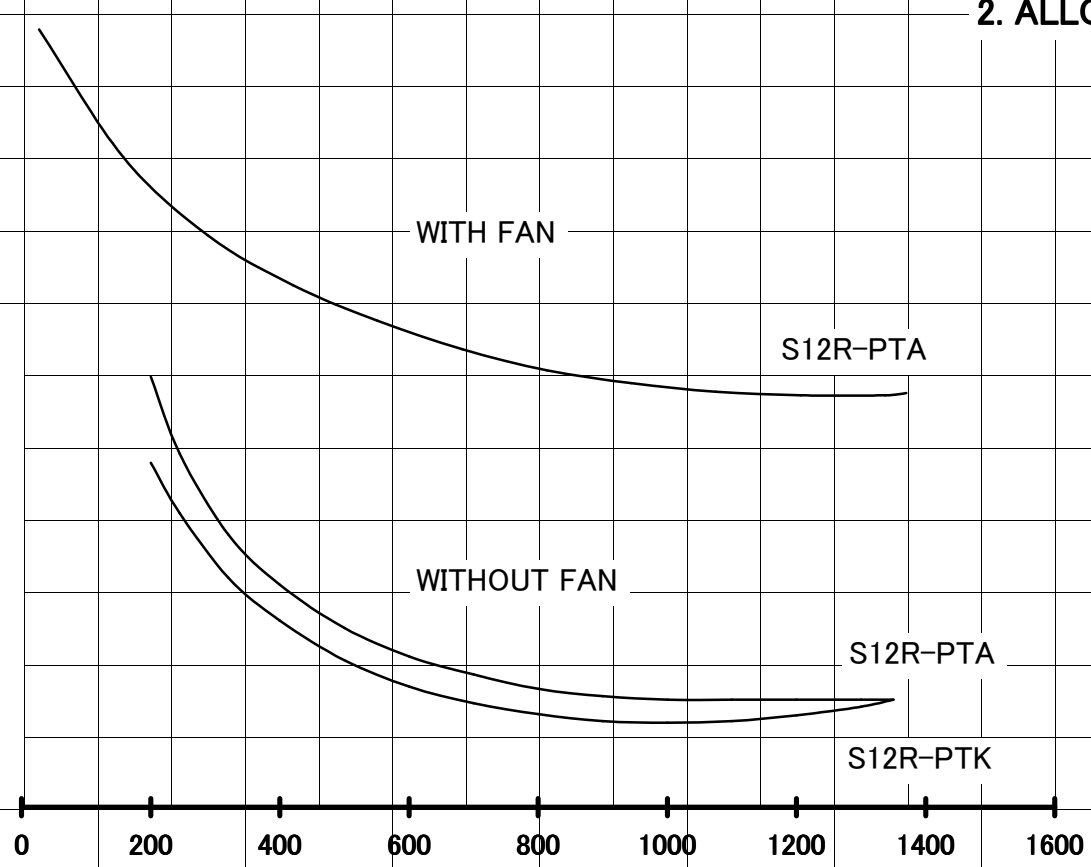

OUTPUT PS

SPECIFIC FUEL CONSUMPTION MODEL : S12R 1500rpm

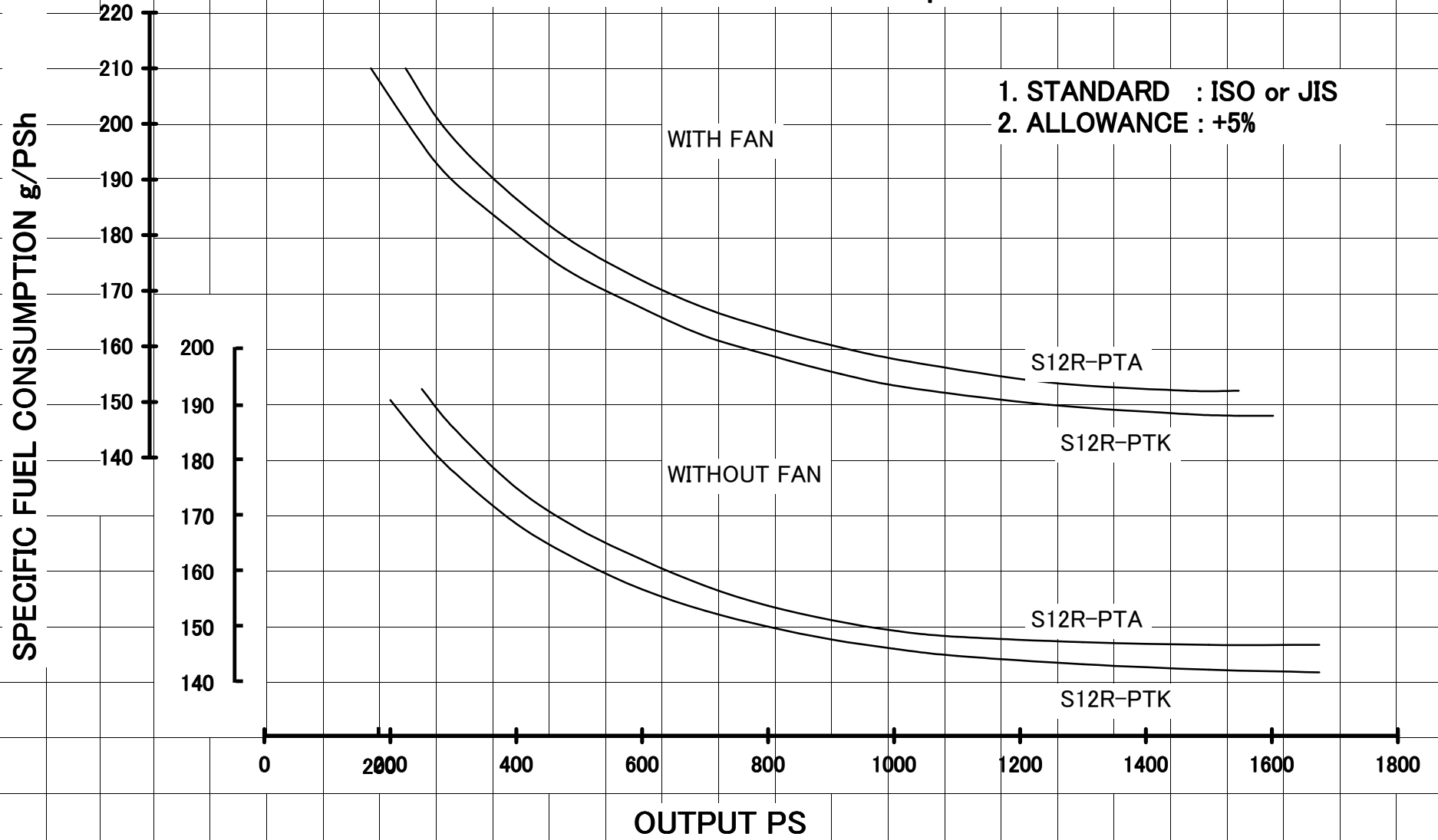

SPECIFIC FUEL CONSUMPTION MODEL : S12R 1800rpm

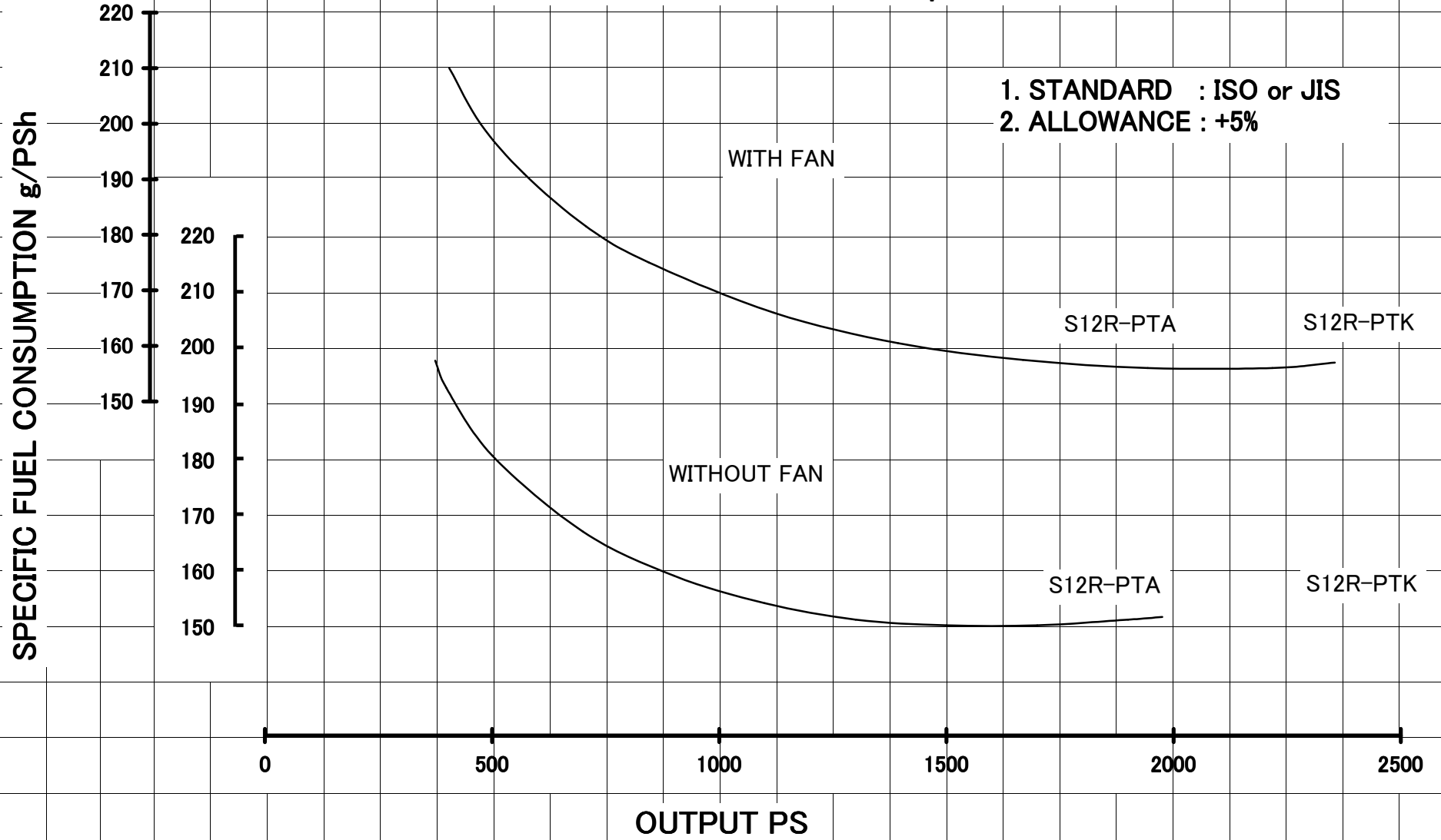

SPECIFIC FUEL CONSUMPTION MODEL : S16R 1200rpm

- 1. STANDARD : ISO or JIS
- 2. ALLOWANCE : +5%

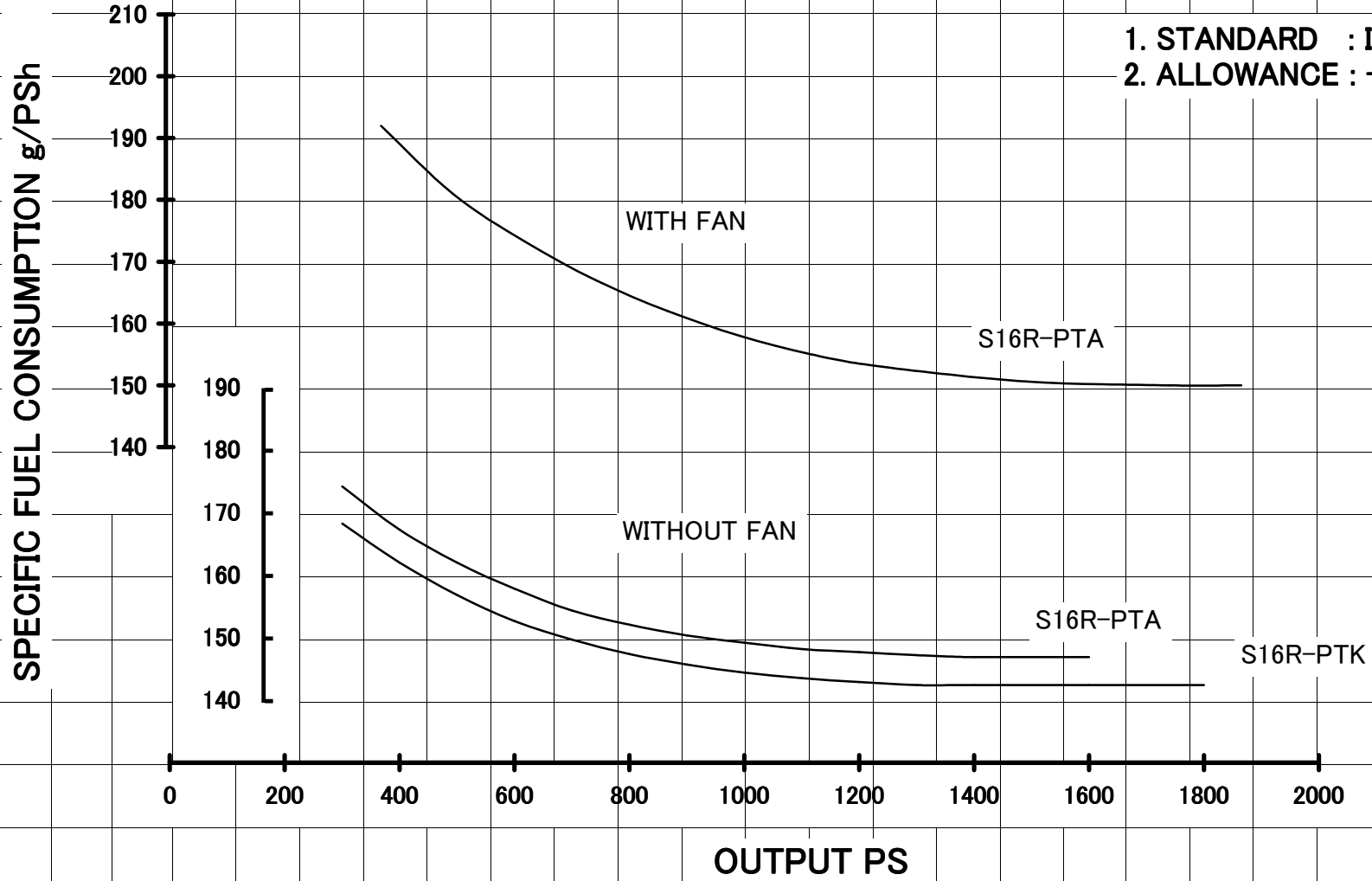

SPECIFIC FUEL CONSUMPTION MODEL : S16R 1500rpm

- 1. STANDARD : ISO or JIS
- 2. ALLOWANCE : +5%

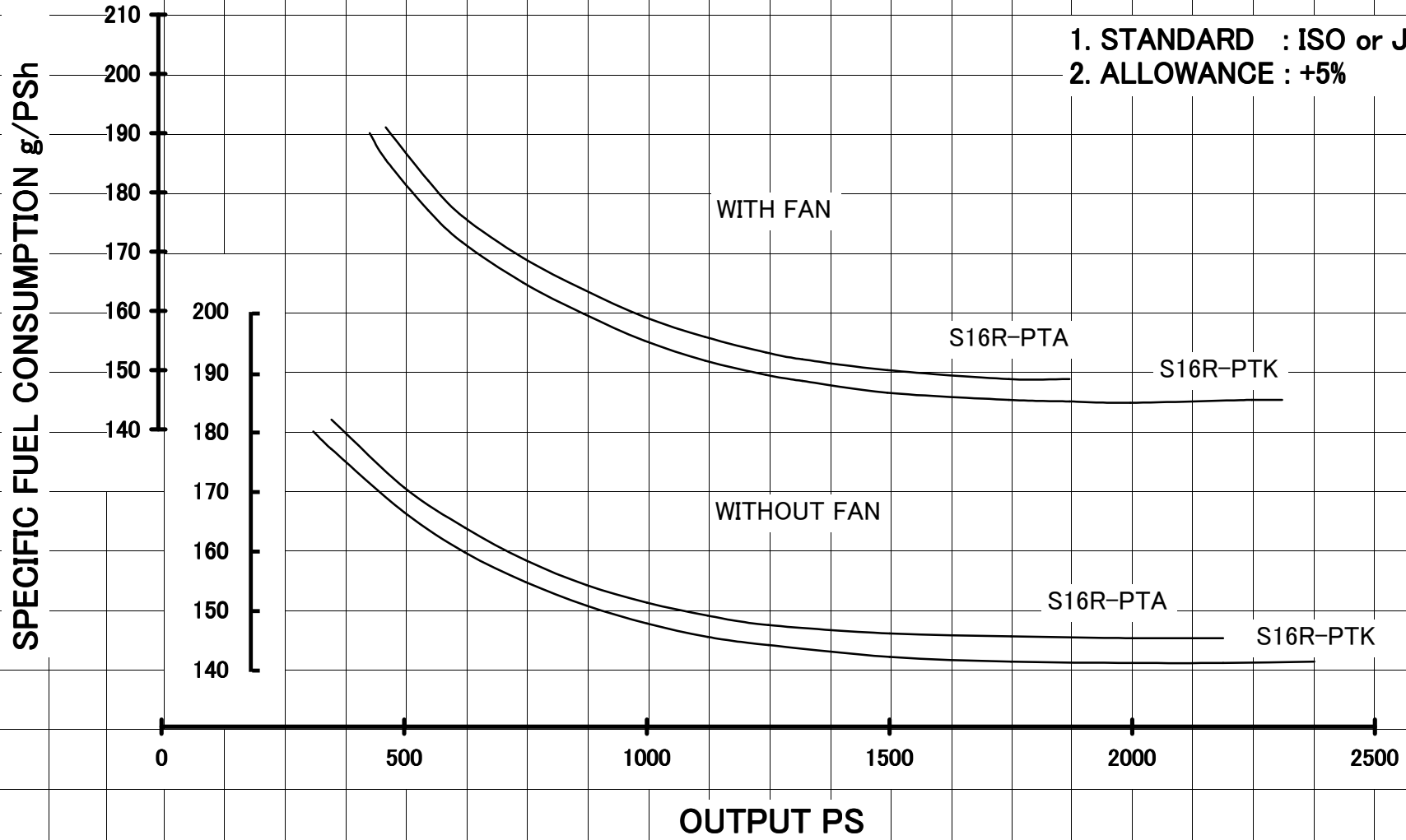

SPECIFIC FUEL CONSUMPTION MODEL : S16R 1800rpm

- 1. STANDARD : ISO or JIS
- 2. ALLOWANCE : +5%

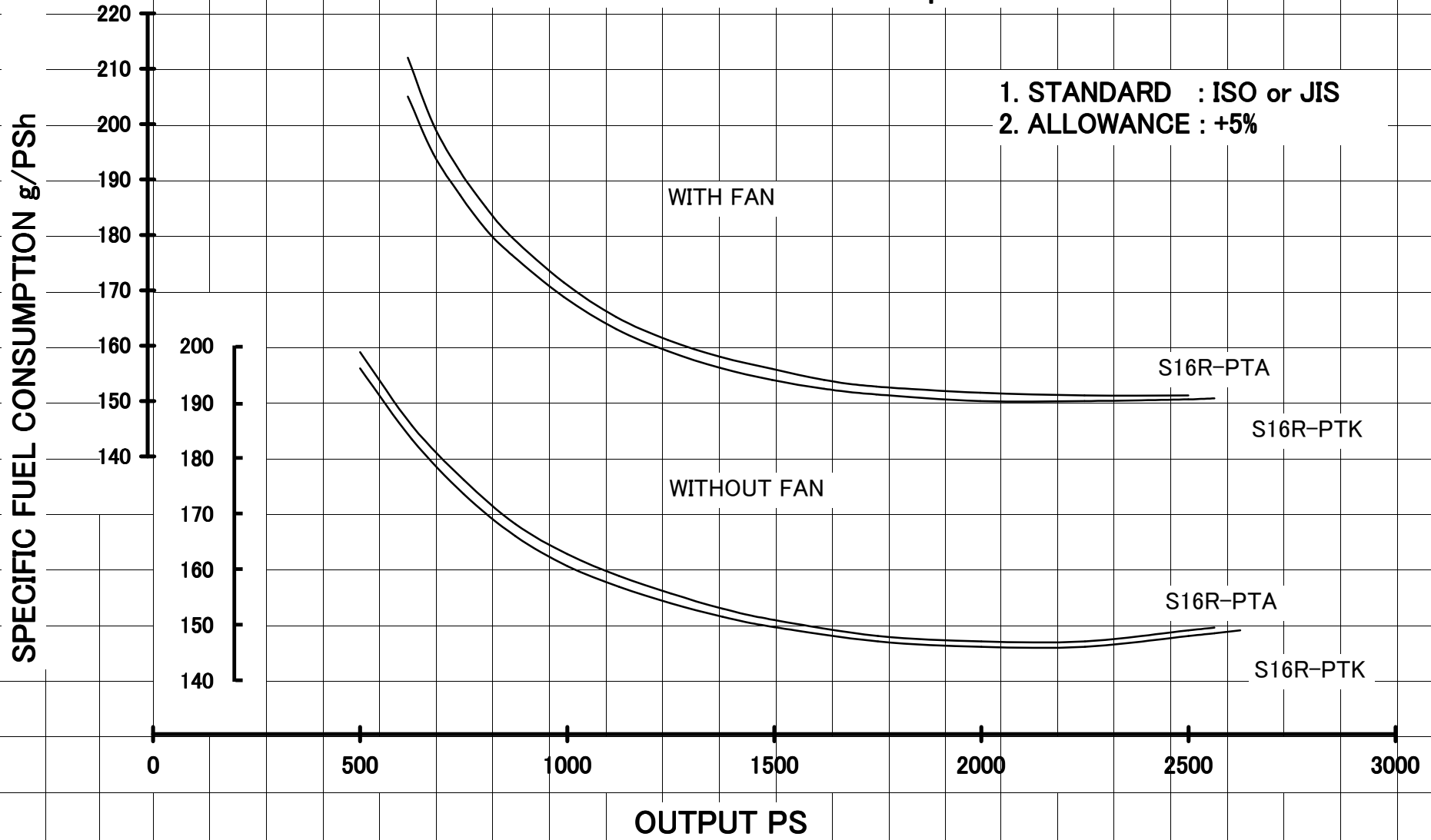

SPECIFIC FUEL CONSUMPTION MODEL : S16R-2 1500rpm

- 1. STANDARD : ISO or JIS
- 2. ALLOWANCE : +5%
- 3. THIS INFORMATION IS SUBJECT TO CHANGE WITHOUT NOTICE

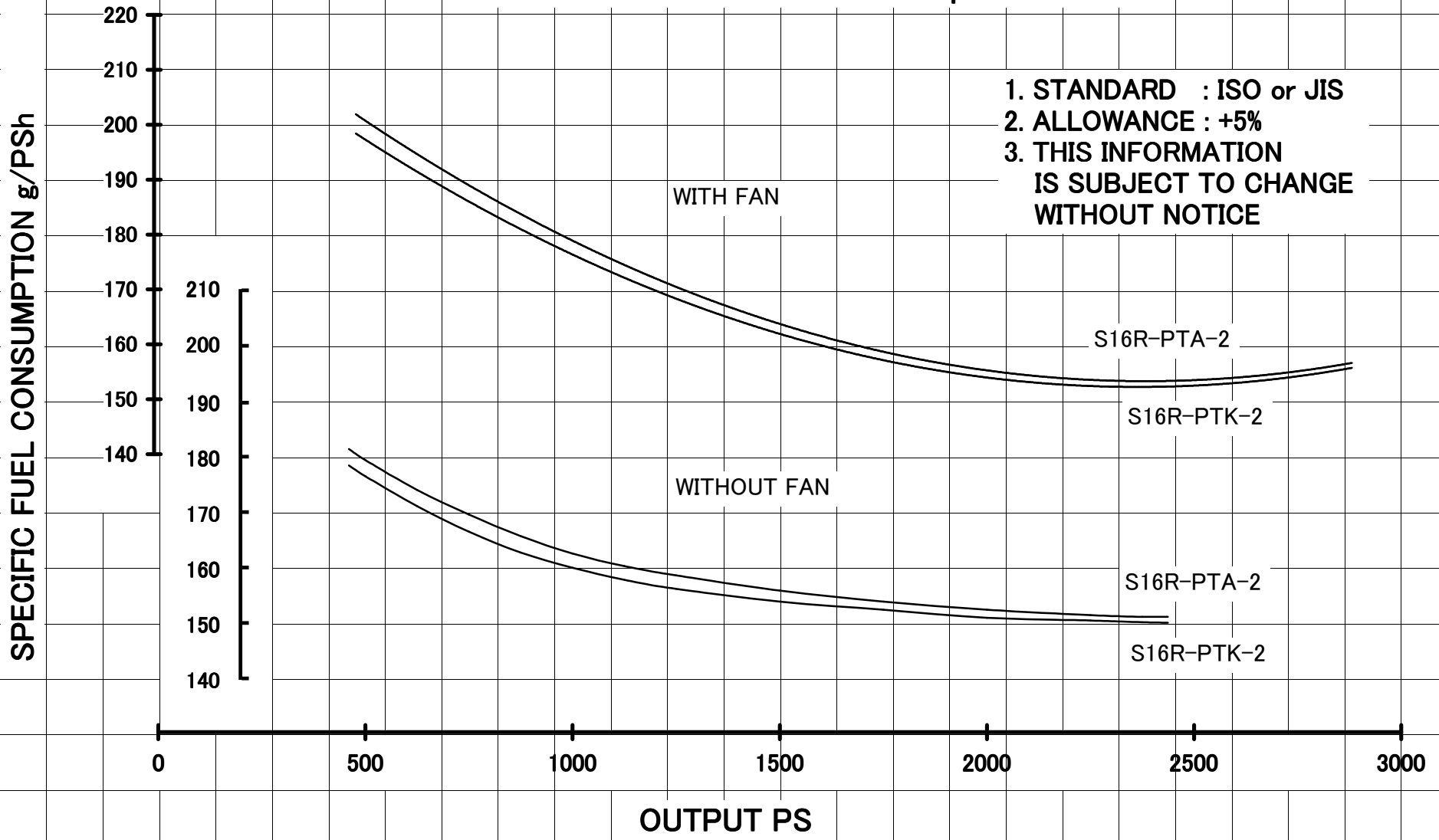

SPECIFIC FUEL CONSUMPTION MODEL : S16R-2 1800rpm

- 1. STANDARD : ISO or JIS
- 2. ALLOWANCE : +5%
- 3. THIS INFORMATION IS SUBJECT TO CHANGE WITHOUT NOTICE

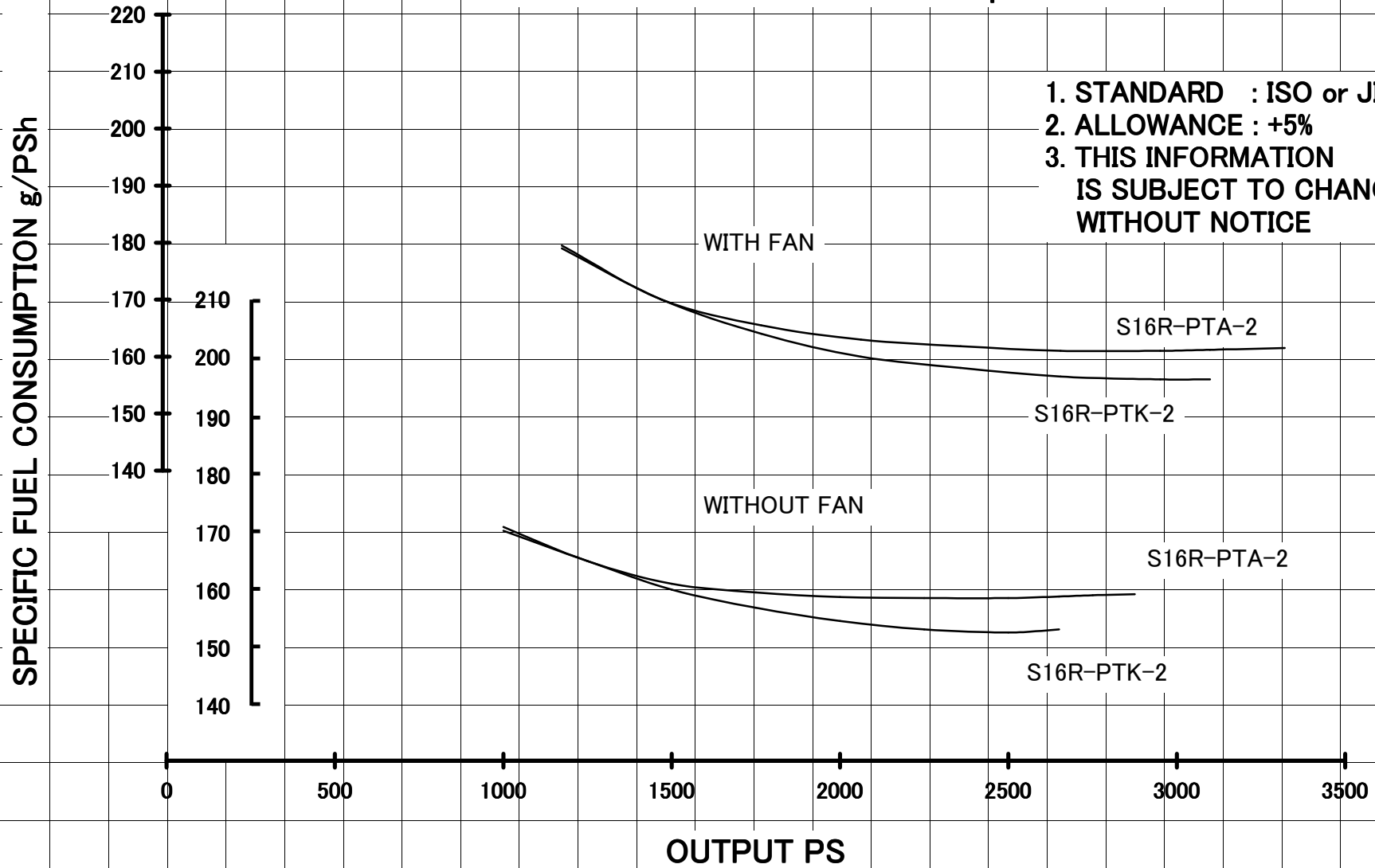

**SPECIFIC FUEL CONSUMPTION
MODEL : S6R2-PTAA 1500rpm**

- 1. STANDARD : ISO or JIS
- 2. ALLOWANCE : +5%

SPECIFIC FUEL CONSUMPTION g/PS_h

200
190
180
170
160
150
140

0 100 200 300 400 500 600 700 800 900 1000 1100

OUTPUT PS

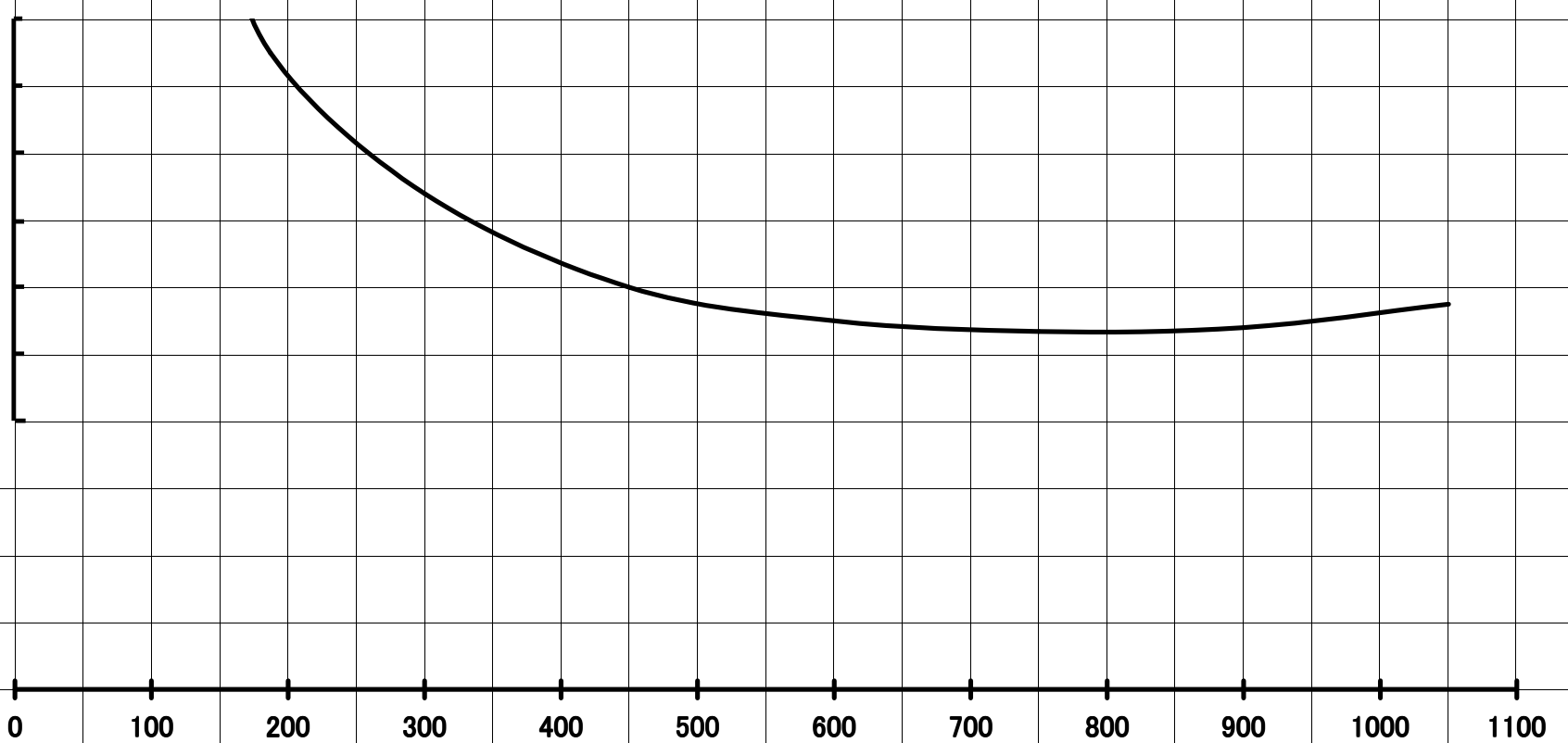

**SPECIFIC FUEL CONSUMPTION
MODEL : S12H-PTA 1500rpm**

- 1. STANDARD : ISO or JIS
- 2. ALLOWANCE : +5%

SPECIFIC FUEL CONSUMPTION g/PS_h

200
190
180
170
160
150
140
190
180
170
160
150
140

0 200 400 600 800 1000 1200 1400 1600

OUTPUT PS

WITH FAN

WITHOUT FAN

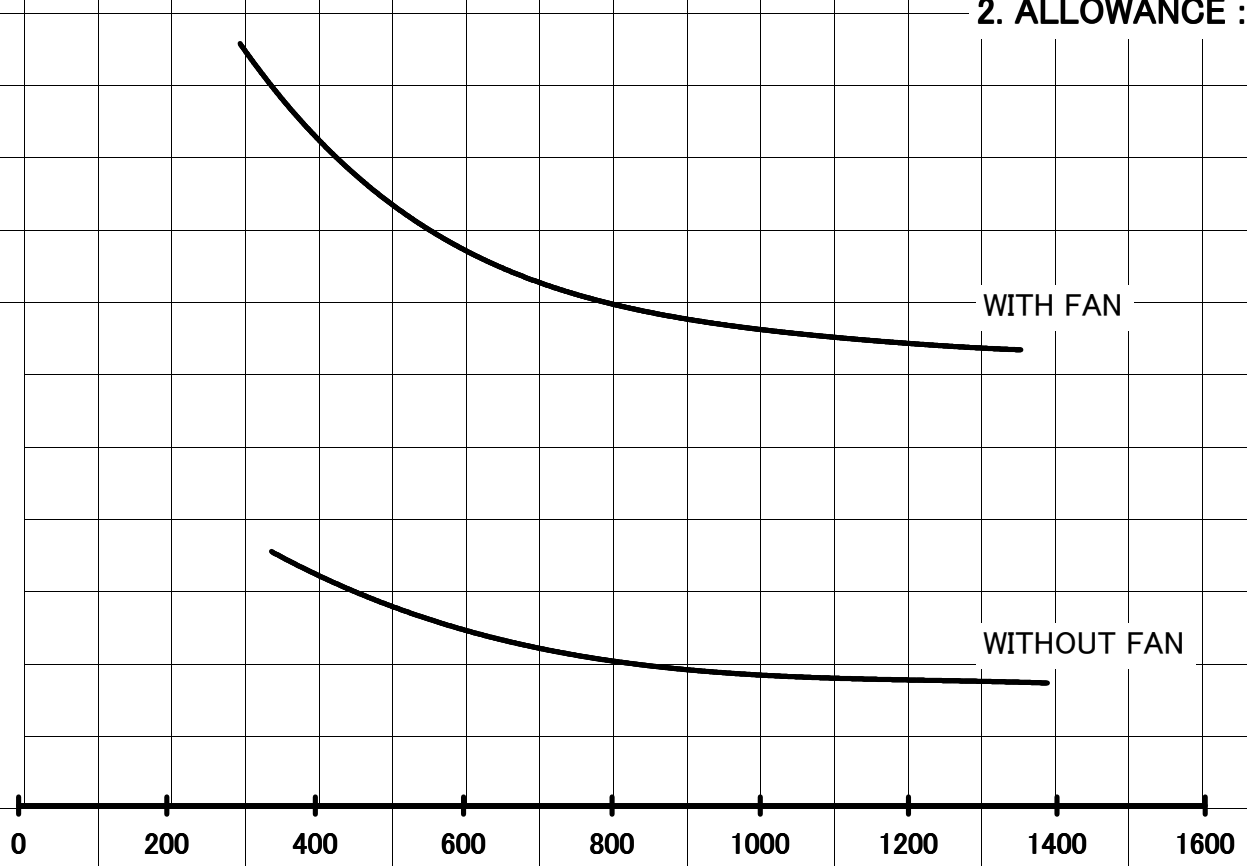

SPECIFIC FUEL CONSUMPTION
MODEL : S12H-PTA 1800rpm

- 1. STANDARD : ISO or JIS
- 2. ALLOWANCE : +5%

SPECIFIC FUEL CONSUMPTION g/PS_h

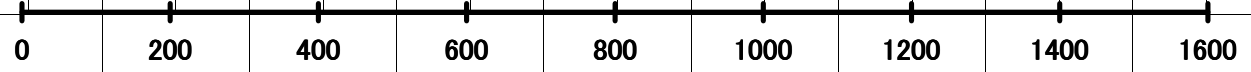
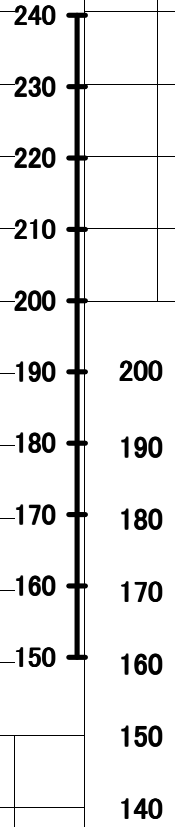

OUTPUT PS

WITH FAN

WITHOUT FAN

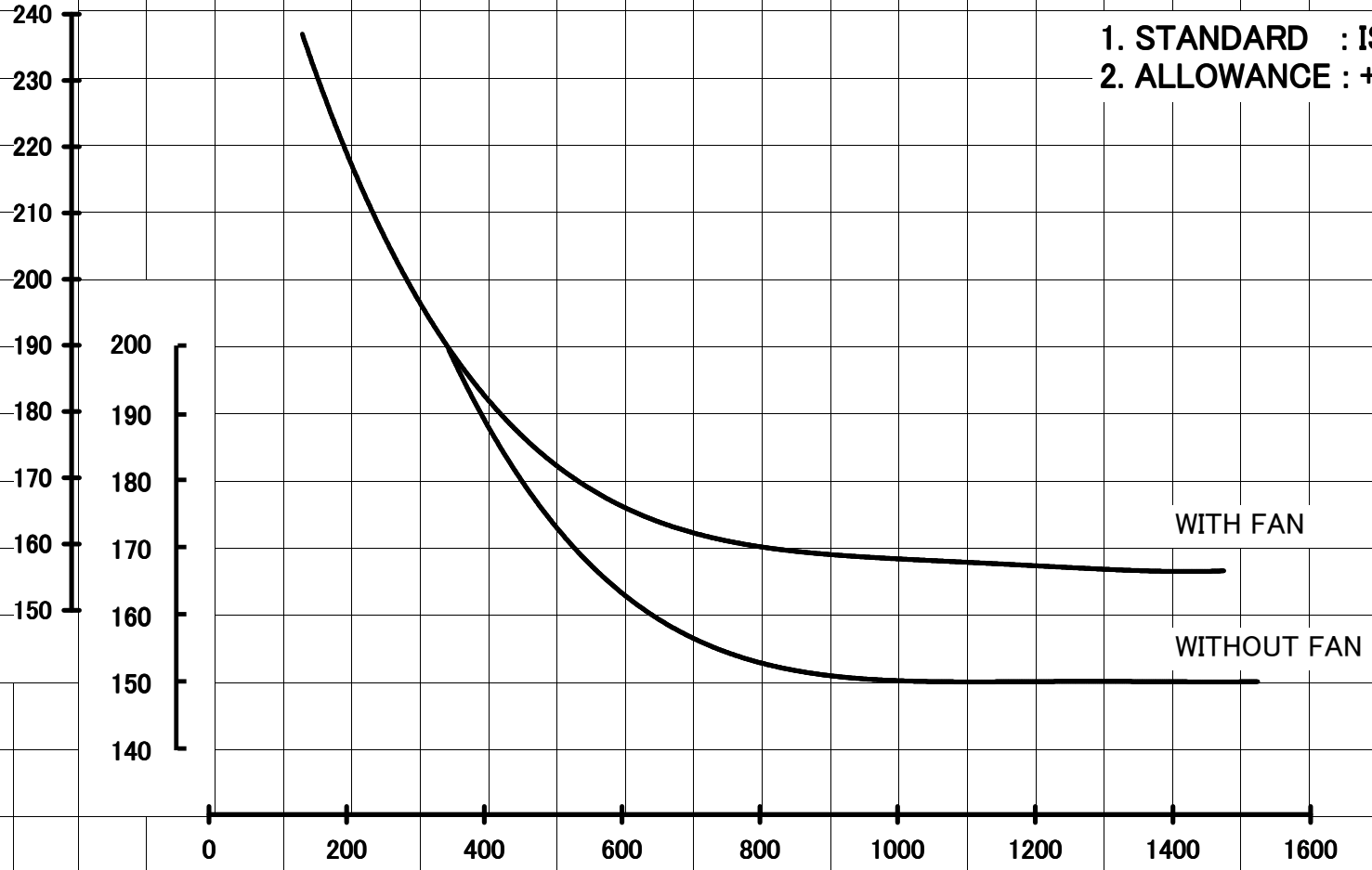

SPECIFIC FUEL CONSUMPTION MODEL : S12R-PTAA2

- 1. STANDARD : ISO or JIS
- 2. ALLOWANCE : +5%

SPECIFIC FUEL CONSUMPTION g/PS_h

200
190
180
170
160
150
140

0 200 400 600 800 1000 1200 1400 1600 1800 2000 2200

OUTPUT PS

1500 rpm

1800 rpm

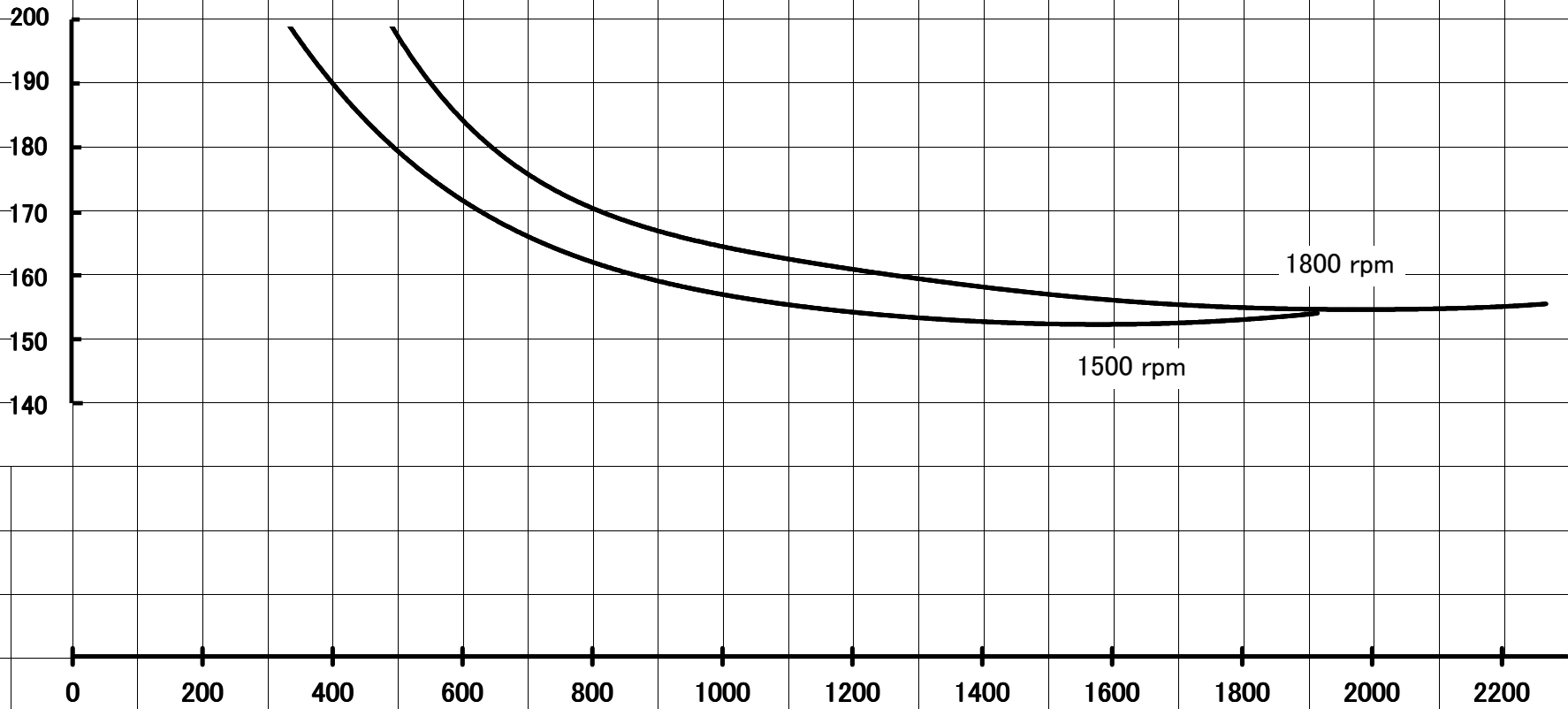

**SPECIFIC FUEL CONSUMPTION
MODEL : S16R-PTAA2**

- 1. STANDARD : ISO or JIS
- 2. ALLOWANCE : +5%

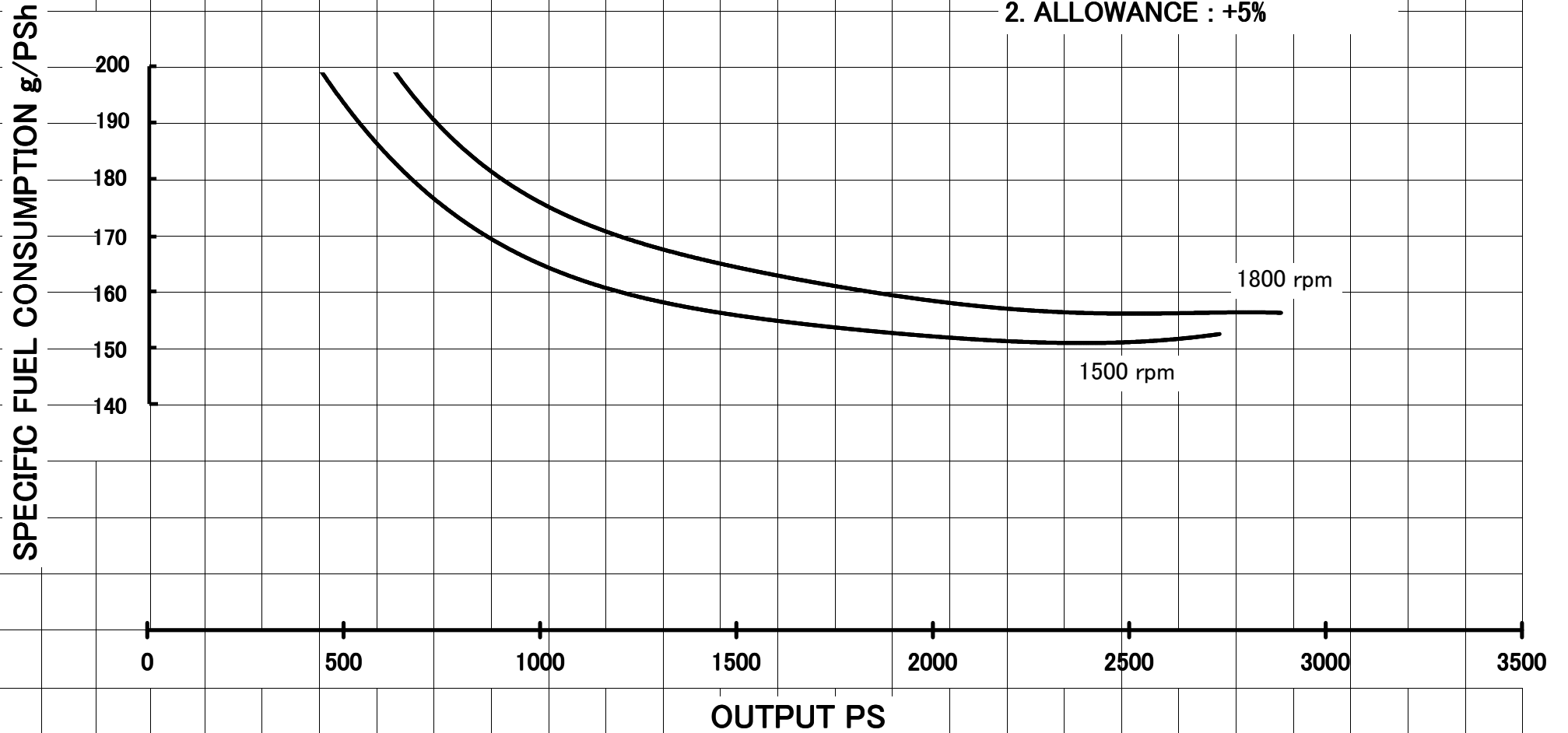

SPECIFIC FUEL CONSUMPTION MODEL : S12R-2 1500rpm

- 1. STANDARD : ISO or JIS
- 2. ALLOWANCE : +5%

SPECIFIC FUEL CONSUMPTION g/PS_h

220
210
200
190
180
170
160
150
140

200
190
180
170
160
150
140

0 200 500 1000 1500 2000 2100

OUTPUT PS

WITH FAN

WITHOUT FAN

PTA2

PTK2

PTA2

PTK2

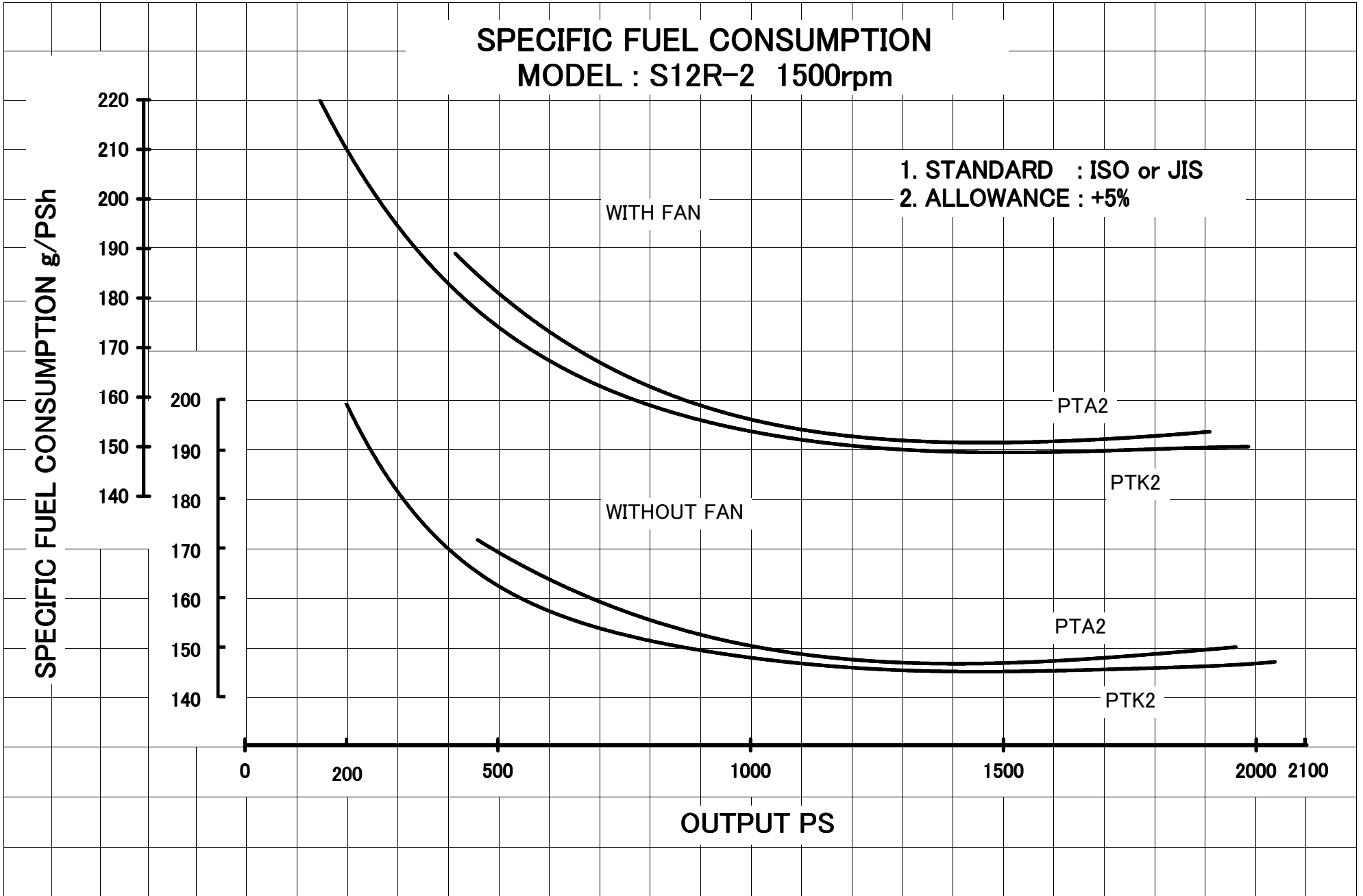

SPECIFIC FUEL CONSUMPTION MODEL : S12R-2 1800rpm

- 1. STANDARD : ISO or JIS
- 2. ALLOWANCE : +5%

